



## ***OWNER'S MANUAL***

***MODEL:***

***A 650 L***

***A 800 L***

***A 1000 L***

***TRACTOR***

**READ THIS MANUAL CAREFULLY BEFORE DRIVING. IT CONTAINS IMPORTANT SAFETY INFORMATION.**

This Owner Manual refers to ANOTHER TRACTOR.

This Owner's Manual must always remain inside your TRACTOR (Legal requirement)

A digital/printable copy is available on [www.anthereurope.com](http://www.anthereurope.com)



To be filled in by your Dealer)

Model Year \_\_\_\_\_

Model Type \_\_\_\_\_

Code number (for spare parts use only) \_\_\_\_\_

VIN Number \_\_\_\_\_

Engine Serial Number \_\_\_\_\_

Registration Plate Number \_\_\_\_\_

## **Dear Customer**

Thank you for purchasing an ANOTHER Tractor, and welcome to our world-wide family of enthusiasts.

We have done this manual to inform you on how to use and maintain the best condition of operation for your Tractor.

If after reading this manual, you still have some questions please do not hesitate to contact your dealer that will be available to help you.

Be sure to visit us online at [www.anthereurope.it](http://www.anthereurope.it) for the latest news and for product and Safety information.

We believe we sets a standard of excellence for all utility and Tractor manufactured in the world today.

With our experience we have gone into the engineering, design, and development of your Tractor, making it the finest machine we've ever produced.

For safe and enjoyable operation of your Tractor, be sure to follow the instructions and recommendations in this owner's manual.

Your manual contains instructions for the maintenance of the Tractor and information about repairs.

Service Manual are available from Dealers, only they can perform major repair and install accessory.

Your dealer knows your Tractor better than anyone and is interested in your total satisfaction, he can perform your service needs during and after the warranty period.

For the most up-to-date owner's manual visit:

[www.anthereurope.it](http://www.anthereurope.it)

Reading and understanding this Owner's Manual is extremely important for your safety and for all operators. Please take your time to read all the pages; if someone else will use the tractor, be sure they take this manual and read and understand it all before they do. This will give you the best knowledge and skills on how to drive in security.

Copyright 2026 ANOTHER EUROPE.

All the information contained within this publication is based on the latest product information at the time of publication.

Due to constant improvement in the design and quality of product components, some minor discrepancies may result between the actual unit and the information presented in this publication.

Descriptions and or procedure in this publication are intended for reference use only. No Liability can be accepted for omission or inaccuracies. Any reprinting or reuse of the depictions and or procedures contained within this publication are intended for reference use only. The original instruction is in Italian language.

Other languages are provided as translation of the original Instruction see the ANOTHER EUROPE website for more details and procedure.

## TABLE OF CONTENTS

<b>TABLE OF CONTENTS</b> .....	5
CERTIFICATE OF PRE-DELIVERY .....	8
OPERATION WARNINGS .....	8
DRIVING THE TRACTOR.....	12
Pre-use inspection check list: .....	20
What to do before starting the engine (Key OFF): .....	21
Driving gear .....	22
Loads transport .....	23
Loading the luggage rack .....	23
Towing a load.....	23
Towing a trailer .....	24
Maximum towing capacity .....	24
Working with your TRACTOR.....	24
Environment and safety warnings.....	25
Security precautions.....	25
General precautions for use and safety .....	25
Reverse.....	26
Downhill driving.....	26
Side guide.....	26
Driving the TRACTOR on snowy surfaces .....	26
Driving techniques.....	27
IMPORTANT ON-PRODUCT .....	30
Engine and TRACTOR identification number location.....	30
Features description and identification.....	31
FUEL .....	56
Recommended fuel .....	56
Fueling procedure .....	56
TIRES.....	57
BREAK-IN PERIOD .....	58
BASIC PROCEDURES .....	59
Starting the engine .....	59
Changing gear selection.....	59
Stopping the engine .....	59
Engine overheat.....	60

Post-operation care .....	60
Storage.....	60
Transporting .....	60
<b>SPECIAL PROCEDURES.....</b>	<b>61</b>
What to do if water is in the CVT.....	61
What to do if water is in the air filter housing.....	61
What to do when TRACTOR is turned over .....	62
What to do when TRACTOR is immersed in water .....	62
<b>MAINTENANCE PROCEDURES .....</b>	<b>63</b>
Air filter .....	63
Air filter removal.....	63
Air filter cleaning and oiling .....	64
Air filter installation .....	64
Maintenance of CVT intake pipe .....	64
Lifting jack position / wheels removal .....	65
Greasing point.....	65
Engine oil .....	66
Oil change and oil filter .....	67
Engine coolant .....	68
Gearbox fluid replacement .....	69
Front differential fluid replacement .....	69
Rear differential fluid replacement .....	70
Spark plug.....	70
Radiator .....	71
Battery.....	71
Fuse.....	72
Brakes .....	73
Suspension adjustment .....	75
Spring preload adjustment .....	75
Muffler spark arrester cleaning and inspection .....	77
<b>MAINTENANCE CHART .....</b>	<b>78</b>
<b>MAINTENANCE SCHEDULE .....</b>	<b>80</b>
Air filter maintenance guideline .....	80
Severe duty use.....	80
Extreme cold condition .....	80
Mud / water use .....	81
Post operation care for mud / water environment.....	81

Exhaust emission control system.....	81
Maintenance schedule.....	82
TROUBLESHOOTING.....	86
FAULT CODES.....	89
WARRANTY.....	90
Registration .....	90
Owner's warranty responsibilities .....	90
TECHNICAL SPECIFICATIONS.....	92
MAINTANANCE LOG .....	93

## CERTIFICATE OF PRE-DELIVERY

### Certificate of Pre-Delivery

Year \_\_\_\_\_ Model \_\_\_\_\_

VIN \_\_\_\_\_

Engine Serial Number \_\_\_\_\_

Key Number \_\_\_\_\_ Km / Hours \_\_\_\_\_

Registration Plate Number \_\_\_\_\_

#### ASSEMBLY / SERVICE / INSPECTION

- SEALED BATTERY – Apply dielectric grease to terminal bolts and install cable. Check Voltage and charge if below 12,8 Volts.
- BATTERY VOLTAGE – Misuse and record the battery voltage after 30 minutes after charger has been removed \_\_\_\_ DCV
- TIRE PRESSURE – Verify Pressure if set to Specification
- WHEEL NUT – Torque to specification
- HANDLEBAR CLAMPS – Torque bolts to specification
- MASTER CYLINDER – Torque bolts to specification
- FRONT TOE ALIGMENT – Verify proper toe setting
- BALL JOINT – Inspect bolts and/or cotter pin
- STEERING POST – Inspect cotter pin
- TIE ROD – Inspect jam nuts and cotter pin
- GREASE FITTING – Check and Grease all the Fitting if needed
- ENGINE OIL – Check level of oil, add if needed
- BRAKE FLUID – Check level of fluid, add if needed in brake master cylinder(s)
- ENGINE COOLANT – Inspect coolant in recovery bottle. Add if needed.
- PARK BRAKE – Verify proper operation
- INTAKE AIRBOX – Inspect hose connection and closing. Inspect filter condition.
- LIGHTS – Verify operation of all lights
- FUEL – Check level of fuel and add if needed
- WIRE HARNESS / HOSE/ LINES – Inspect wire, hoses, and line from kinks, pinching and sign of abrasion.
- COSMETIC INSPECTION – Inspect the TRACTOR for damage and proper fit and finish.

DEALERSHIP NAME \_\_\_\_\_ # \_\_\_\_\_

ASSEMBLED BY \_\_\_\_\_

DATE \_\_\_\_\_ / \_\_\_\_\_ / \_\_\_\_\_

SIGNATURE

STAMP

**Certificate of Pre-Delivery**

Year \_\_\_\_\_ Model \_\_\_\_\_

VIN \_\_\_\_\_

Engine Serial Number \_\_\_\_\_

Key Number \_\_\_\_\_ Km / Hours \_\_\_\_\_

Registration Plate Number \_\_\_\_\_

**TEST DRIVE**

- ENGINE – Starting acceleration and smoothness.
- IDLE SPEED – Verify when cold and hot the engine idle properly.
- TROTTLE – With engine idling and transmission in Neutral, swing the handlebar through entire travel range and verify proper and smooth operation.
- ENGINE THROTTLE - Verify proper operation and throttle free play.
- AUXILIARY SHUT OFF SWITCH - Verify proper operation.
- BRAKES - Verify proper operation. Torque bolts to specification
- DRIVELINE – Verify smooth operation
- CLUTCH / TRANSMISSION – Verify proper shifting and transmission engagement/ indicator lights must correspond with gears.
- 2WD/4WD/DIFFERENTIAL(S) – Verify proper operation.
- REVERSE SPEED LIMITER – Verify operation and overdrive control.
- INSTRUMENTATION – Verify operational reading.
- WINCH (If equipped) – Verify proper operation.
- SUSPENSION / STEERING – Verify adjustment, stability and operation.
- ENGINE COOLANT Inspect coolant in recovery bottle between Min and Max after test drive, add if necessary.
- LEAKEAGE – Check for leakage and verify proper connection of oil / exhaust / fuel / coolant / brake fluid fitting, inspect hoses for sign and abrasion.
- CLEAN – Wash and clean the TRACTOR before delivery.

TEST RIDDEN BY \_\_\_\_\_

DATE \_\_\_\_\_ / \_\_\_\_\_ / \_\_\_\_\_

SIGNATURE

STAMP

**Certificate of Pre-Delivery**

Year \_\_\_\_\_ Model \_\_\_\_\_

VIN \_\_\_\_\_

Engine Serial Number \_\_\_\_\_

Key Number \_\_\_\_\_ Km / Hours \_\_\_\_\_

Registration Plate Number \_\_\_\_\_

**DELIVERY TO CUSTOMER**

- WARRANTY REGISTRATION FORM – Completed and signed.
- OWNERS MANUAL – Emphasize the importance of reading for customer Safety and Servicing of TRACTOR/ Explain periodic maintenance responsibilities.
- WARRANTY POLICY – Explanation / Limit / Requirements.
- KEYS - Record Key Number.
- CONTROLS – Show location and function.
- BELT LIFE – Discuss proper operation procedure operating and proper use of High and Low Gear Range.
- BREAK IN PROCEDURE – Review as outline in Owner’s Manual.
- STORAGE / FUELING / TRANSPORTATION – Review as outline in the owner’s manual.
- TOOL KIT – Show location.
- SAFETY FEATURES – Review all safety features of TRACTOR operation for new operation.
- DRIVING PROCEDURE – Review Operator driving procedure outlined in the Owner’s Manual.
- PRE-DELIVERY CERTIFICATION – I certify that pre-delivery inspection and service have been perform on this TRACTOR in accordance with the instructions issued by ANTHER.

DEALERSHIP NAME \_\_\_\_\_ # \_\_\_\_\_

DELIVERED BY \_\_\_\_\_

DATE \_\_\_\_\_ / \_\_\_\_\_ / \_\_\_\_\_

SIGNATURE

STAMP

**Certificate of Pre-Delivery**

Year \_\_\_\_\_ Model \_\_\_\_\_

VIN \_\_\_\_\_

Engine Serial Number \_\_\_\_\_

Key Number \_\_\_\_\_ Km / Hours \_\_\_\_\_

Registration Plate Number \_\_\_\_\_

**CUSTOMER ACCEPTANCE**

- I have reviewed the ANOTHER warranty Policy / Policies
- I have inspected the TRACTOR and it meets my satisfaction.
- I understand the importance of following the Owner's Manual and instructions.
- I understand the importance of using all safety features.
- I understand the importance of all operation following the operator driving procedures in the Owner's Manual.

---

(Name of dealership and person who inform the Customer)

CUSTOMER NAME \_\_\_\_\_

CUSTOMER SIGNATURE

DATE \_\_\_\_\_ / \_\_\_\_\_ / \_\_\_\_\_

STAMP

## OPERATION WARNINGS

NOTE: The following illustration is a general description. Your model may be slightly different.

### **WARNING**

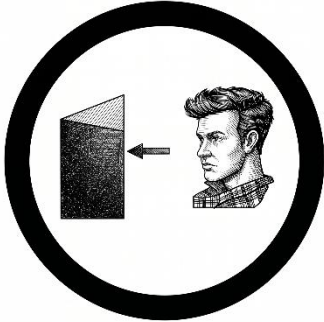

#### **POTENTIAL HAZARD**

Inexperience driving a TRACTOR is a significant risk factor for accidents.

#### **WHAT CAN HAPPEN**

If the operator does not know how to operate the TRACTOR correctly in different situations and under different circumstances, the risk of accidents will increase significantly.

#### **HOW TO AVOID DANGER**

Beginners and inexperienced operators should complete training courses. Then, they should practice the skills learned in the course according to the operation techniques described in this operation guide.

For more information about training courses, please contact an authorized dealer.

### **WARNING**



#### **POTENTIAL HAZARD**

Failure to follow the age recommendations for this TRACTOR.

#### **WHAT CAN HAPPEN**

Failure to comply with this age recommendation can lead to serious injury or death. Even if the individual falls within the age range for which this TRACTOR is recommended, they may not be qualified to drive the TRACTOR.

#### **HOW TO AVOID THE HAZARD**

No person without a license and information on the use of the TRACTOR under the age of 18 is allowed to drive this TRACTOR.

**! WARNING**

**POTENTIAL HAZARD**

Not following the warnings for use of the TRACTOR.

**WHAT CAN HAPPEN**

Smoke or open flames or sparks in or near the refueling place or stored gasoline can cause the fire.

**HOW TO AVOID THE HAZARD**

Always refuel with the engine off, outdoors or in a well-ventilated area. If gasoline spills on your skin or clothes, immediately wash them with soap and water and change clothes.



**! WARNING**

**POTENTIAL HAZARD**

Using TRACTORS in enclosed environments.

**WHAT CAN HAPPEN**

It is possible to have exhaust emission poisoning, which can be dangerous to your safety.

**HOW TO AVOID THE HAZARD**

Always operate the TRACTOR in open areas



**! WARNING**

**POTENTIAL HAZARD**

Transporting flammable or hazardous materials may cause an explosion.

**WHAT CAN HAPPEN**

This can cause serious injury or death.

**HOW TO AVOID THE HAZARD**

Never carry flammable or hazardous materials.



**! WARNING**



**POTENTIAL HAZARD**

Using this TRACTOR under the influence of drugs or alcohol.

**WHAT CAN HAPPEN**

It could seriously affect your judgment.

It could cause you to react more slowly.

It could affect you to balance and perception.

It could result in an accident or death.

**HOW TO AVOID THE HAZARD**

Never operate this TRACTOR under the influence of drugs or alcohol.

**! WARNING**

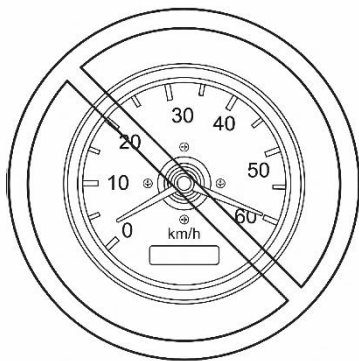

**POTENTIAL HAZARD**

Operating this TRACTOR at excessive speed.

**WHAT CAN HAPPEN**

Increases your chances of losing control of the TRACTOR, which can result in an accident.

**HOW TO AVOID THE HAZARD**

Always travel at a speed appropriate to the terrain, operating conditions, and your experience.

**! WARNING**



**POTENTIAL HAZARD**

Driving this TRACTOR without wearing an approved/certified helmet, eye protection and protective clothing.

**WHAT CAN HAPPEN**

The following items concern all TRACTOR's operator:

- Driving without an approved helmet increases the chances of a severe head injury or death in the event of an accident.

- Driving without eye protection can result in an accident and increases the chances of a severe injury in the event of an accident.

- Driving without protective clothing increases the chances of severe injury in the event of an accident.

## HOW TO AVOID THE HAZARD

Always wear an approved/certified helmet that fits properly. You should also wear:

- Eye protection (goggles or face shield)
- Gloves and boots
- Long sleeved shirt or jacket
- Long pants.

## ⚠️ WARNING



### POTENTIAL HAZARD

Attempting wheelies, jumps and other stunts.

### WHAT CAN HAPPEN

Increases the chance of an accident, including an overturn.

### HOW TO AVOID THE HAZARD

Never attempt stunts, such as wheelies or jumps. Do not try to show off.

## ⚠️ WARNING



### POTENTIAL HAZARD

Failure to inspect the TRACTOR before operating. Failure to properly maintain the TRACTOR.

### WHAT CAN HAPPEN

Increase the possibility of an accident or equipment damage.

### HOW TO AVOID THE HAZARD

Always inspect your TRACTOR prior to every time you use it to make sure the TRACTOR is in safe operating condition. Always follow the inspection and maintenance procedures and schedules described further in this Owner's Manual.

## **WARNING**

### **POTENTIAL HAZARD**

Failure to exercise due caution when operating this TRACTOR in unfamiliar terrain.

### **WHAT CAN HAPPEN**

You may run into hidden rocks, bumps, or holes, without enough time to react.

It may cause the TRACTOR to overturn or cause loss of control.

### **HOW TO AVOID THE HAZARD**

Go slowly and use extreme caution when operating in unfamiliar terrain. When operating the TRACTOR, always pay attention to changing terrain conditions.



## **WARNING**

### **POTENTIAL HAZARD**

Operating on excessively steep hills.

### **WHAT CAN HAPPEN**

A TRACTOR can tip over more easily on extremely steep slopes than on level surfaces or small inclines.

### **HOW TO AVOID THE HAZARD**

Never use a TRACTOR on hills that are too steep for the TRACTOR or your skills. Practice on smaller hills before attempting larger ones.



## **WARNING**

### **POTENTIAL HAZARD**

Climbing hills improperly.

### **WHAT CAN HAPPEN**

This could result in loss of TRACTOR control or overturning.

### **HOW TO AVOID THE HAZARD**

Always follow proper hill climbing procedures described later in this manual. Always check the terrain thoroughly before driving on hills. Never drive-up hills with excessively slippery or loose surfaces. Shift your weight forward. Never open the throttle suddenly. The TRACTOR could tip backward. Never drive to the top of a hill at high speed. On the other side of the hill there may be an obstacle, a sharp drop-off, or another TRACTOR or person.



## **WARNING**

### **POTENTIAL HAZARD**

Going down a hill improperly.

### **WHAT CAN HAPPEN**

This could result in loss of TRACTOR control or overturning.

### **HOW TO AVOID THE HAZARD**

Always follow proper hill descent procedures as described in this Owner's Manual.

**NOTE:** A special braking technique is required when descending a hill. Always check the terrain thoroughly before beginning the descent. Shift your body weight rearward. Never descend a hill at high speed. Avoid descending at an angle that would cause the TRACTOR to lean sharply to one side. Whenever possible, descend a hill in a straight line.



## **WARNING**

### **POTENTIAL HAZARD**

Improper overcoming obstacles.

### **WHAT CAN HAPPEN**

This could result in loss of TRACTOR control or a collision.

The TRACTOR could overturn.

### **HOW TO AVOID THE HAZARD**

Before driving on new terrain, check for obstacles. Never attempt to overcome large obstacles, such as large rocks or fallen trees. When overcoming obstacles, always follow the procedures described later in this manual.



## **WARNING**

### **POTENTIAL HAZARD**

Driving a TRACTOR through deep or fast-flowing water.

### **WHAT CAN HAPPEN**

Tires may float, causing loss of traction and TRACTOR control, which could lead to an accident.

### **HOW TO AVOID THE HAZARD**

Never use this TRACTOR in fast-flowing water or in water deeper than specified later in this Operator's Manual. Before attempting to drive through water, check its depth and current. The water level should not exceed the level of the tires. Remember that wet brakes may have reduced braking effectiveness. Test the brakes after leaving the water. If necessary, apply them several times to allow the brake pads to dry.



## **WARNING**

### **POTENTIAL HAZARD**

Incorrect operation when reversing.

### **WHAT CAN HAPPEN**

You could hit an obstacle or person behind the TRACTOR, resulting in serious injury

### **HOW TO AVOID THE HAZARD**

When engaging in reverse gear, make sure there are no obstacles or people behind the TRACTOR. Once it is safe to drive, drive slowly.



## **WARNING**

### **POTENTIAL HAZARD**

Driving on frozen waterways.

### **WHAT CAN HAPPEN**

Braking on ice can cause serious injury or death. Icy surfaces reduce traction.

### **HOW TO AVOID THE HAZARD**

Never drive a TRACTOR on a frozen surface until you are sure that the ice is thick and solid enough to support the TRACTOR and its load, as well as the force generated by the moving TRACTOR.



## DRIVING THE TRACTOR

To fully appreciate the pleasure and thrill of driving, extensive experience is required. However, some may be novices, so a thorough understanding of driving rules is essential before starting.

Driving properly is paramount – everyone has their own unique personality and driving and handling methods vary.

Before driving, fully familiarize yourself with the controls and overall performance of your TRACTOR.

Practice driving in appropriate, safe areas, and be prepared to react if you lose control.

Higher speeds require more experience, knowledge, and the wearing of more protective equipment.

Driving conditions vary depending on the location and weather. Weather conditions can drastically change driving conditions, making control difficult or affecting vision.

**WARNING!** Driving on sand is different from driving in snow, through forests, or through swamps. Environmental factors vary in each location, requiring a better understanding of the local environment and driving skills, along with common sense and due care.

Never assume you'll arrive safely everywhere. Sudden changes caused by potholes, depressions, riverbanks, soft or hard surfaces, or other critical conditions can cause the TRACTOR to roll over or become unstable. If the TRACTOR begins to roll over, it is best to exit immediately and stay away from the overturned TRACTOR.

DO NOT drive after taking drugs. This can cause problems, serious injury, or even death.

The information in this owner's manual is for guidance only. It is recommended to always check with your local authorities for information on age restrictions, license types, and areas permitted by your TRACTOR.

**WARNING!** Perform a pre-drive inspection before each drive to detect any potential problems that could occur during operation. The pre-drive inspection can help you monitor component wear and deterioration before they become a problem. Correct any problems you discover to reduce the risk of a breakdown or crash.

Before using this TRACTOR, the operator should always perform the following pre-drive inspection check list.

**PRE-USE INSPECTION CHECK LIST:**

<b>ELEMENTS TO INSPECT</b>	<b>INSPECTION TO BE PERFORMED</b>
Engine oil	Check engine oil level.
Coolant	Check coolant level
Brake fluid	Check fluid level
Leaks	Check for any leaks under TRACTOR.
Throttle lever	Operate the throttle lever several times to ensure it operates freely. It must return to idle position when released.
Parking brake	Apply parking brake and check if it operates properly.
Tires	Check tire pressure and condition of the tires.
Wheels	Check the wheels for damage or abnormal play, and check that the wheel nuts are tight.
Radiator	Check the cleanliness of the radiator.
Drive shaft boots	Check the condition of driveshaft boots and protectors condition.
Seat	Check that the driver's seat is in place and properly locked.
Load	<p>If you're carrying cargo, adhere to the load limit. Make sure the cargo is properly secured to the rear rack.</p> <p>If you're towing a trailer or other equipment:</p> <ul style="list-style-type: none"> <li>- Check the condition of the tow hitch and tow ball.</li> <li>- Adhere to the load limit.</li> <li>- Make sure the trailer is properly attached to the hitch.</li> </ul>
Storage	Check if glove box is properly locked.
Storage compartments	Check if rear storage compartments are closed properly.
Chassis and Suspension	Check for any debris under the TRACTOR, frame or suspension and clean it thoroughly.

**WHAT TO DO BEFORE STARTING THE ENGINE (KEY OFF):**

<b>ELEMENTS TO INSPECT</b>	<b>INSPECTION TO BE PERFORMED</b>
Multifunction light switch	Check the operation of the multifunction light switch control lamps. Check for alarm messages on the multifunction gauge.
Lights	Check operation and cleanliness of the headlights and the taillight. Check operation of the high and low beam. Check operation of the brake light.
Fuel level	Check the fuel level.
Steering	Check if steering operates freely by turning from side to side.
Gear lever	Check operation of the gear lever (P, R, N, H and L).
2WD/4WD selector	Check operation of the 2WD/4WD selector.
Brakes	Drive forward slowly a few meters and apply brakes gradually to test them. The brakes must fully apply. The lever and pedal must return to their original position when released.
Engine emergency stop switch	Check that the engine emergency stop switch is working properly.
Ignition switch	Check that the ignition switch is working properly by starting and stopping the engine.

## DRIVING GEAR

The actual weather conditions should help you decide how to dress. Dress for the coldest weather expected. Thermal underwear in contact with the skin also provides good insulation. It is important that the operator always wears the proper protective clothing and clothing, including an approved helmet, eye protection, boots, gloves, a long-sleeved shirt, and pants. This type of clothing will protect you from some of the small dangers you may encounter along the way. The operator should never wear loose clothing such as a scarf that could become entangled in the TRACTOR or on tree and shrub branches. Depending on the condition, anti-fog glasses or sunglasses may be required. Different colored lenses available for glasses or sunglasses help you distinguish terrain variations. Sunglasses should only be worn during the day.

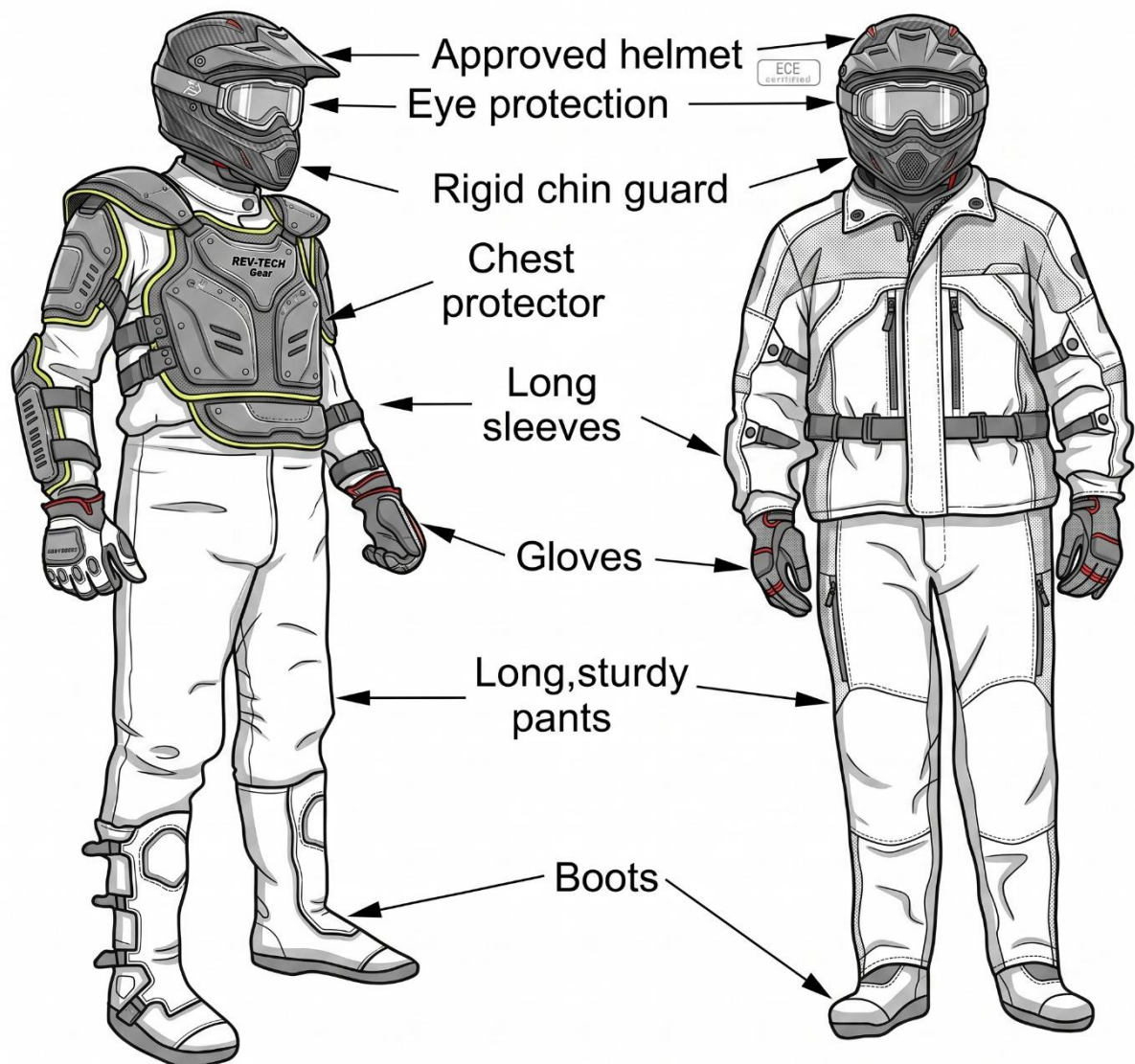

**Riders with appropriate riding gear**

## LOADS TRANSPORT

Any load carried on the TRACTOR will affect the TRACTOR's handling, stability, and braking distance. For this reason, do not exceed the load limits indicated by the TRACTOR manufacturer. Refer to the MAXIMUM LOADS in this manual. Always ensure that the load is secured, distributed correctly, and cannot interfere with proper control. Always keep in mind that the "load" could slip or fall and create an accident. Avoid loads that could protrude sideways and become entangled or entangled in bushes or other obstacles. Avoid covering and obstructing the headlights or brake light with the load.

Safely reduce speed based on terrain conditions when transporting goods or towing a trailer. Allow more distance for braking. Always secure the load as low as possible on the rear rack to reduce the effect of a higher center of gravity.

Safely reduce speed according to ground conditions when transporting goods or towing a trailer, allow for more braking distance. Always secure the load as low as possible on the rear rack to reduce the effect of a higher center of gravity.

Evenly distributed Includes rear rack, rear storage compartment, rear storage compartment and tab load.

## LOADING THE LUGGAGE RACK

When loading or unloading, do not exceed the permissible load limit. Refer to the table of MAXIMUM TRANSPORTABLE LOADS.

Secure the load as low as possible: A high load can increase the TRACTOR's center of gravity, which can reduce stability. Place the load on the roof rack as evenly as possible.

Secure the load on the luggage rack. Do not secure the load to other parts of the TRACTOR, if not properly secured, a load may slip or fall, hitting the driver, passenger, or may move while driving, affecting the handling of the TRACTOR.

Tall objects can impair the driver's visibility and can be blunt in the event of an accident. Loads protruding from the side can become entangled or entangled in bushes, branches, or other obstacles. Avoid covering and obstructing the brake lights with the load. Make sure that no cargo protrudes outside the roof rack and that the load does not interfere with visibility or control of the TRACTOR. Do not overload the luggage rack.

Never carry containers of gasoline or hazardous liquids on the roof rack.

## TOWING A LOAD

Never pull a load by securing it to the bumper or roof rack; This can cause the TRACTOR to tip over. Use only the towbar (if installed) to tow a load. In an emergency situation, use the recovery hitch to retrieve a stranded TRACTOR.

When pulling loads, be sure to maintain the tension of the tow rope when pulling and releasing.

When pulling loads, be sure to brake progressively.

When transporting a load, observe the maximum towing capacity.

**WARNING!** Loosening or jerking can cause the rope to break.

Reduce your speed when towing and steer gradually. Avoid uphill descents and rough terrain, never attempt steep descents. Allow more distance for braking, especially on inclined surfaces.

## TOWING A TRAILER

Driving this TRACTOR with a trailer greatly increases the risk of rollover, especially on inclined slopes. If you are using a trailer behind your TRACTOR, make sure that its towbar is compatible with that of your TRACTOR.

Reduce your speed when towing a trailer and steer gradually. Avoid climbs, descents and rough terrain. Never attempt steep descents. Allow more distance for braking, especially on inclined surfaces. Never tow a trailer on a grade steeper than 15°.

Improper loading of a trailer can cause loss of control. Observe the maximum recommended towing capacity and the maximum load on the nameplate (refer to the MAXIMUM TOWING CAPACITY table).

Always ensure that the load is evenly distributed and securely secured on the trailer; An evenly balanced trailer is easier to control. This TRACTOR may require an additional stopping distance if you are carrying heavy loads, especially on inclined surfaces.

Always set the gear lever to "L" (Slow Gear) when towing a trailer – in addition to providing more torque, Slow Gear operation helps account for increased load. Do not operate the TRACTOR faster than 16km/h when towing.

Keep the TRACTOR's speed at a slow pace.

When stopping or parking, put on the handbrake of the TRACTOR and block the wheels of the trailer from possible movements.

Use caution when disconnecting a loaded trailer; its load may spill on you or others.

When towing a trailer, observe the maximum towing capacity indicated on the TRACTOR nameplate and in this owner's manual.

## MAXIMUM TOWING CAPACITY

Even if the towing and braking capacity is more than double the weight of the TRACTOR, it remains at the discretion of the user to adjust the weight to be towed according to the following variants: terrain and weather conditions as better specified below.

If the TRACTOR is used to tow off-road, the towing and braking capacity of the trailers varies depending on the conditions of the terrain which can be: grassy, muddy, wet, slippery, icy, gravel, snowy, sandy, or with conditions of significant slopes, such as a country road that is little traveled or with previously existing canals.

## WORKING WITH YOUR TRACTOR

Your TRACTOR can help you perform a number of different light tasks ranging from clearing snow to towing wood or transporting goods. A variety of accessories are available from your authorized dealer. However, always respect the load and capacity of the TRACTOR. Overloading the TRACTOR can overload components and cause failure. To prevent possible injury, it is equally important to follow the instructions and warnings that accompany the accessory. Avoid physical exertion when lifting or towing heavy loads or feeding people in the TRACTOR.

## ENVIRONMENT AND SAFETY WARNINGS

One of the advantages of this TRACTOR is that it can take you safely on dirt roads and beaten paths where allowed. However, one must always respect nature and the right of others to enjoy it. Do not drive in environmentally sensitive areas. Do not drive on forest crops or shrubs, or cut down trees or fences, do not skid with tires and destroy the soil. "Walk lightly".

This TRACTOR can cause fire if some dry debris accumulates near the exhaust or other engine hot spots and catches fire and then falls into dry grass. Avoid driving in wet areas, through tall grass meadows, where debris can accumulate. If you were to drive in those areas, inspect and remove all debris from the engine and hot spots.

Wildlife hunting is illegal in many areas. Wildlife can die of exhaustion after being chased by a motor TRACTOR. If you encounter animals on the trail, stop and observe silently and cautiously. It will be one of the best memories of your life.

Do not throw rubbish. Do not light campfires unless you have permission to do so, and then only away from dry areas. The hazards you may create on the trail can cause injury to others or yourself.

Respect farmland. Always obtain permission from the landowner before driving on private land. Respect crops, farm animals and property boundaries.

Finally, do not pollute streams, lakes or rivers and do not modify the engine or exhaust system, or remove any of its components.

## SECURITY PRECAUTIONS

To reduce the risks associated with driving on groomed terrain, several safety measures are essential, including Preliminary Terrain Assessment: Before driving on the terrain, a thorough assessment should be made to identify any hidden hazards.

Driver training: Drivers must be properly trained to meet the challenges of driving on groomed terrain.

Use of suitable TRACTORS: It is important to use TRACTORS that are suitable for the type of terrain and operating conditions.

## GENERAL PRECAUTIONS FOR USE AND SAFETY

Care, prudence, experience, and driving skills are the best precautions against the dangers of operating a TRACTOR, especially in difficult conditions. When in doubt, if you are concerned that your TRACTOR may not pass an obstacle or a stretch of terrain safely, it is essential to always choose an alternative route. In off-road driving, it is essential to proceed at a speed appropriate to visibility and one's own path evaluation skills. Constantly observe the ground for sudden changes in slope, obstacles such as rocks or stumps, which can compromise the stability of the TRACTOR and cause rollovers.

Never operate the TRACTOR if the controls are not working properly.

Regularly check the condition of the brakes, tires, lights, and other essential components.

When reversing, make sure that there are no people or obstacles behind the TRACTOR. Proceed slowly and avoid sharp turns.

When stationary or parked, always engage the gear lever in the " P " PARK position and apply the parking brake, especially on slopes.

On very steep slopes or when heavily loaded, it is advisable to block the wheels with stones or other objects to prevent unwanted movement of the TRACTOR.

## REVERSE

Reversing can be particularly dangerous, as the view to the rear is often restricted and the risk of rollover is greater.

Before reversing, make sure that there are no people, animals or obstacles behind the TRACTOR. The speed must be extremely low in order to have time to react in an emergency. Sharp turns in reverse can easily cause tipping over.

Check your rearview mirrors frequently to get the widest possible view. It is crucial to remain seated when reversing. Standing can cause weight to shift forward, especially when suddenly braking or unintentional acceleration. Make sure you have a firm grip on the handlebars to maintain control of the TRACTOR. Keep your feet firmly resting on the footpegs for added stability.

## DOWNHILL DRIVING

Remember that this TRACTOR may be able to climb steeper inclines than it can safely descend. Therefore, it is essential to ensure that there is a safe path to descend a slope before tackling it. Remember, caution is always the best ally when driving downhill. Evaluate the route carefully, adapt the speed to the conditions and do not hesitate to seek advice from experts or participate in safe driving courses.

## SIDE GUIDE

Avoid driving on side slopes. If necessary, do so with extreme caution. Tilting sideways on steep inclines could cause it to tip over. Also, slippery or loose surfaces could cause uncontrollable side sliding. Do not attempt to spin the TRACTOR downhill. Avoid any objects or dips that will intensify the lifting of one side of the TRACTOR higher than the other, thus causing it to tip over.

## DRIVING THE TRACTOR ON SNOWY SURFACES

During the pre-use inspection, pay special attention to locations in the TRACTOR where snow and/or ice may accumulate as they may obstruct the visibility of the taillight and reflectors, block ventilation openings, block the radiator and fan, and interfere with the movement of the control levers, switches, and brake pedal. Before using the TRACTOR, check that the steering, accelerator and brake levers and foot controls are operating without interference.

Whenever driven on a snowy driving course, tire grip is generally reduced, causing the TRACTOR to react differently to the operator's control inputs. On low-grip surfaces, steering responses are not as crisp and precise, stopping distances are lengthened and acceleration becomes slow. This will only result in the tires slipping and possibly oversteering skidding of the TRACTOR. Avoid sudden braking. This could result in the TRACTOR sliding in a straight line. Again, the best advice is to reduce your

speed safely. Anticipate a maneuver so that you have time and distance to regain total control of the TRACTOR before it goes out of your control. As you drive on a loose snowy surface, snow dust will be collected in the wake turbulence of the moving TRACTOR and carried on contact and accumulate or melt on some exposed components, including rotating parts such as brake discs. Water, snow or ice can affect the response time of the brake system. Even when you don't need to reduce your TRACTOR's speed, brake frequently to prevent ice or snow build-up and dry brake pads and discs. During this operation, in low-risk driving situations, you will test the level of grip and keep yourself attentive to how the TRACTOR reacts to your control inputs. Always keep the brake pedal, footrests, footrests, brake and throttle levers clear of snow and ice. Frequently clean snow from your seat, grips, headlights, taillights, and reflectors.

The depth of the snowpack can hide rocks, tree stumps or other objects and, if wet, can totally hinder drivability as the TRACTOR gets bogged down or completely loses traction in the muddy snow. Look far ahead and always be alert to any visible clues that might indicate the presence of such obstacles. When in doubt, change path. Avoid driving on any frozen body of water before checking that the ice supports safely. Remember that a given thickness of ice may be sufficient to support a snowmobile but not a TRACTOR of identical weight due to the smaller load-bearing surface area of the four contact tires compared to that of the track and skis of a snowmobile. To maximize comfort and avoid frostbite, always wear appropriate clothing and protective equipment for the weather conditions you will be exposed to during your run.

At the end of each use, it is a good idea to clean the TRACTOR body and all moving components (brakes, steering components, transmissions, controls, radiator fan, etc.) from any accumulation of snow or ice. Wet snow will turn to ice during the closure period and become more difficult to remove on the next pre-use inspection.

## DRIVING TECHNIQUES

Driving the TRACTOR at too high a speed can be dangerous and cause injury. Accelerate gradually to proceed safely. Statistics show that accidents and injuries result from reckless driving. Always remember that this TRACTOR is heavy! Its self-weight can crush you in the event of a fall and lock you under the overturned TRACTOR.

This TRACTOR is not designed to make jumps, nor is it able to fully absorb the high impact energy generated during landings from jumps. Wheelies can cause the TRACTOR to tip over the driver. Both practices have a high risk for the driver and should be avoided at all times. To maintain proper control, it is strongly recommended that you keep your hands on the handlebars and within reach of all controls. The same goes for your feet. To minimize the possibility of leg or foot injury, always keep your feet on the footrests. Do not direct your toes outward or stretch your feet to facilitate turning as they can be hit or caught in passing obstacles or may come into contact with the wheels. Always use proper driving techniques to avoid overturning the TRACTOR on hills and rough terrain and when cornering.

Even though there is a proper suspension system on this TRACTOR, there are conditions where driving on rough terrain will make you feel uncomfortable and can even cause a back injury. It is often necessary to drive in a squatting position. Slow down and let your flexed legs absorb some of the energy from the impact. Do not drive on sidewalks. They are intended for pedestrian use.

Water can be a major hazard. If the depth is too deep, the TRACTOR may "float" and tip over. Before crossing a ford, check the depth and current of the water. The water level must not exceed the tires. Be wary of slippery surfaces such as rocks, grass, logs, etc., both in the water and on its banks. Loss of traction may occur. Do not attempt to enter the water at high speed. The water will act as a brake and may throw you out of the TRACTOR, on the ground.

Water will affect your TRACTOR's braking ability. Be sure to dry the brakes by applying them several times after the TRACTOR has left the water.

Muddy or swampy terrain may be encountered near water. Be prepared for sudden dips or changes in depth. Similarly, watch out for hazards such as rocks, logs, etc., partially covered by vegetation.

If your route crosses frozen streams, avoid them and change your route.

When driving in winter and in temperatures close to freezing, be aware of the danger of icy roads. Ice or snow reduces braking distances and causes loss of control of the TRACTOR in the event of sudden safety maneuvers.

Driving on sandy terrain, sand dunes, or snow is another unique experience, but there are some basic precautions that should be observed. Wet, deep, or fine sand/snow can create a loss of traction and cause the TRACTOR to slip, sag, or get bogged down. If so, look for a more solid foundation. Again, the best advice is to slow down and pay attention to the conditions.

When driving your TRACTOR on sandy terrain, it is recommended that you equip your TRACTOR with a high-visibility flag. This will help make your location more visible to others than the next sand dune. Proceed with caution if you see another safety flag in front of you. Because the antenna-type safety flag can snag and bounce off the body if caught, do not use it in areas where there are low branches or obstacles.

Driving on loose stones or gravel is very similar to driving on ice. They will affect the steering of the TRACTOR, causing it to slide and tip over especially at high speeds. In addition, the braking distance can be affected. Remember that "shooting" the throttle or sliding can cause loose stones to be ejected backwards in another pilot's path. Never do this deliberately.

If you slip or slide, it can be helpful to turn the handlebars in the direction of the slide until you regain control. Never lock the brakes and lock the wheels. Respect and follow all marked signs. They are there to help you and others. Obstacles in the "path" must be crossed with caution. This includes loose rocks, fallen trees, slippery surfaces, fences, posts, embankments and depressions. You should avoid them whenever possible. Remember that some obstacles are too large or dangerous to walk through and should be avoided. Small rocks or fallen trees can be safely crossed, approaching at an angle of 90. Stand on the footrests while keeping your knees flexed. Adjust your speed without losing momentum and don't "shoot" the throttle. Hold the handlebar firmly. Place your body weight backwards and proceed. Do not attempt to lift the front wheels of the TRACTOR off the ground.

Be aware that the object may be slippery or move when crossing.

When driving on hills or slopes, two things are very important. Be prepared for slippery surfaces or terrain variations and obstacles and use proper body positioning.

### **Downhill**

Keep your body weight back. Stay seated. Gradually apply the brake to prevent skidding. Do not coasting using only engine compression or in neutral.

Decelerating while negotiating a slippery descent could cause the TRACTOR to skid. Maintain a steady speed and/or accelerate slightly to regain control. Try to avoid steep inclines. If you were not careful, you could tip over when coming down the slopes.

### **Uphill**

Before you tackle a climb, keep these things in mind. Uphill climbing should only be attempted by experienced operators. Start on slopes that are not very steep. Always drive straight uphill and keep your body weight forward to the top of the hill. Keep your feet on the footpegs, shift into a lower gear and accelerate before you start climbing. Try to maintain a steady speed and use the throttle gradually to avoid acceleration. A sharp slope or change in terrain or rolling a wheel over an obstacle could have a big impact on stability as it will lift the front of the TRACTOR increasing the risk of rollover. Some slopes are too steep to stop or recover safely after a failed climbing attempt. Try to avoid steep inclines.

If you are not careful, you may tip over when climbing hills. If the climb is too steep and you cannot proceed or the TRACTOR starts to roll backwards, apply the brake being careful not to slip. Do not attempt to hold on to the TRACTOR if it begins to tip over. Stay away. Do not go over the crest of the hill at high speed. Obstacles may be present, including abrupt elevation changes.

## IMPORTANT ON-PRODUCT

Carefully read the decals with instructions and symbols with safety information.

Any person who drives this TRACTOR must read and understand this information before driving.

## ENGINE AND TRACTOR IDENTIFICATION NUMBER LOCATION

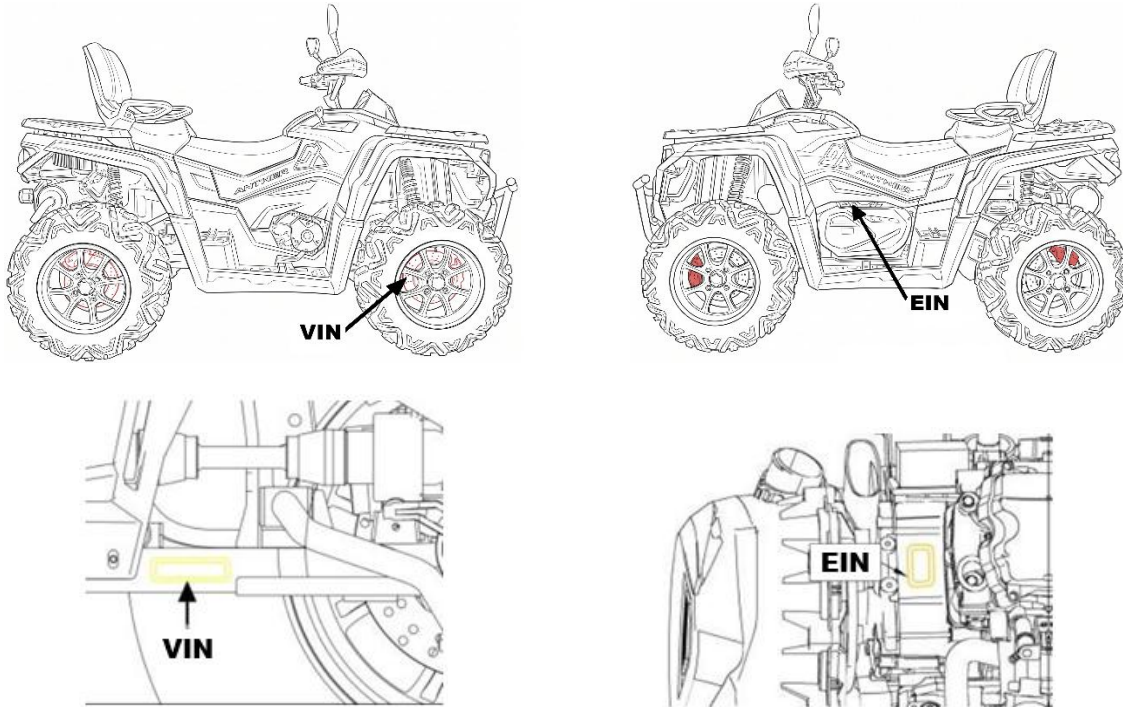

1. EIN (Engine Identification Number on left side of the engine – see drawing above)
2. VIN (TRACTOR Identification Number on the front right side of the frame – see drawing above)

## FEATURES DESCRIPTION AND IDENTIFICATION

NOTE: Some controls/instruments/equipment are optional.

1. Brake pedal
2. Selector switch
3. Mechanical parking brake
4. Throttle lever
5. Foot pegs
6. Multi-function switch
7. Multifunction gauge
8. Rear view mirror
9. Rear storage
10. License plate lamp
11. Trailer socket
12. Fender (If equipped)
13. Front Seat
14. Gear lever
15. Front / Rear bumper
16. Headlight / Turn indicators/ Hazard warning light
17. Towing hook / Winch
18. Brake Lever
19. Rear seat
20. Towing hitch
21. Tail/brake lights
22. Rear reflectors
23. Cargo rack
24. Electrical heating handlebar grip  
(If equipped)
25. Ignition key / Tether key
26. Auxiliary DC socket
27. USB port
28. Handlebar cover
29. Tool kits

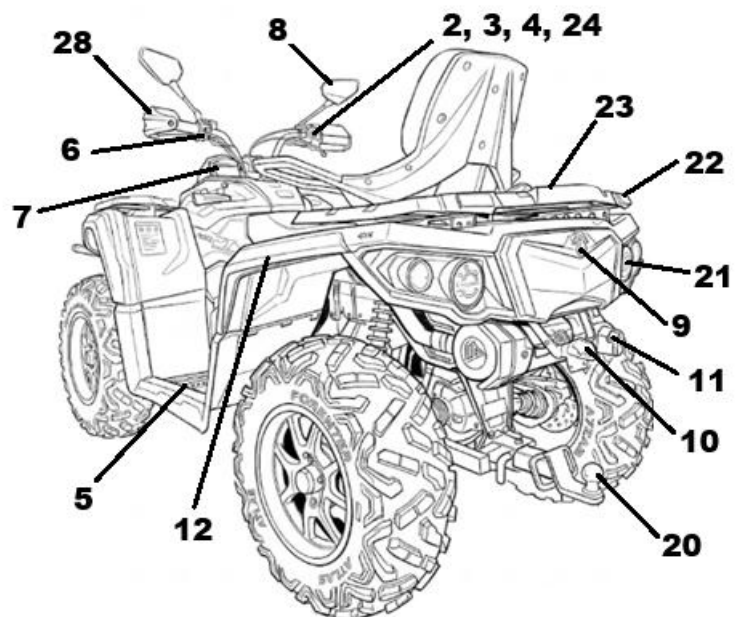
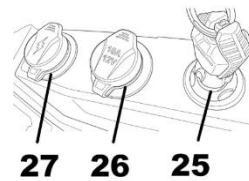
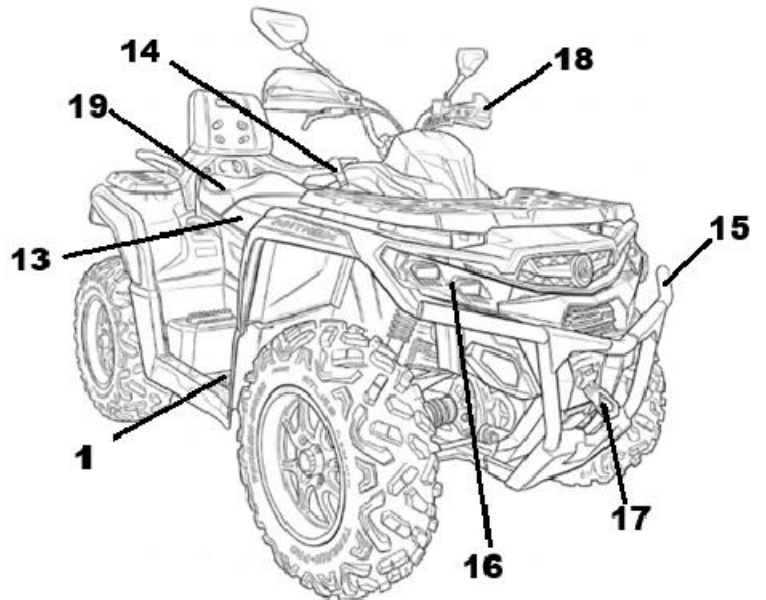

### **(1) Brake pedal**

The brake pedal is located on the right side of the TRACTOR.

When you press the brake pedal and apply the rear brake, the TRACTOR gradually slows down.

After release, the brake pedal will automatically return to its normal state.

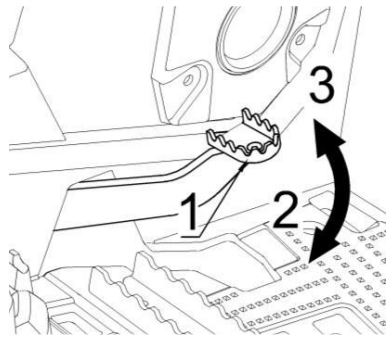

1. Brake pedal
2. To decelerate the TRACTOR
3. Normal position

### **(2) Selector switch**

The 2WD (2 wheels drive) / 4WD (4 wheels drive) selector is located on the right side of the handlebar. This selector allows you to choose between 2WD and 4WD when the TRACTOR is stationary.

Use the selector and button on the handlebar to decide what type of traction you want to have according to your needs. By moving the plastic selector that covers the button, you can press the button that allows you to engage or disengage front differential.

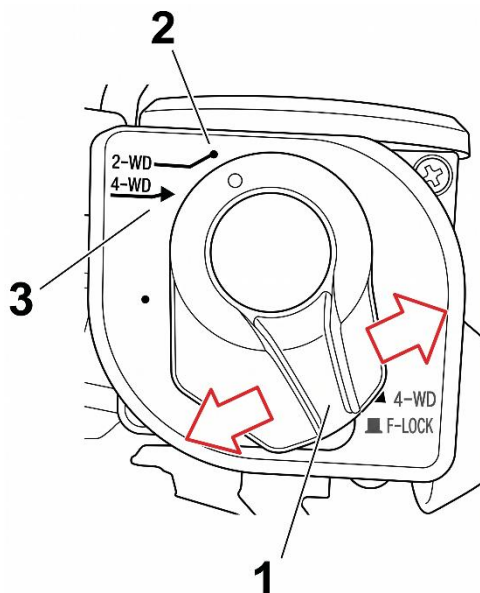

1. Selector for 2WD or 4WD
2. 2WD position (2 wheels drive)
3. 4WD position (4 wheels drive)

NOTE: all choices on the traction of the TRACTOR must be made from a standstill with the engine at idle rpm. When the selector is used while driving mechanical damage may occur.

NOTE: If the rear wheels are spinning, release the throttle and wait for the engine to return to idle before selecting all-wheel drive mode.

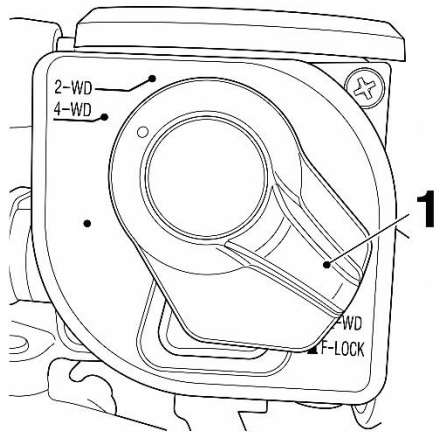

### 4-Wheel Drive (4WD) mode

Push selector 1 to the right to activate 4WD mode.

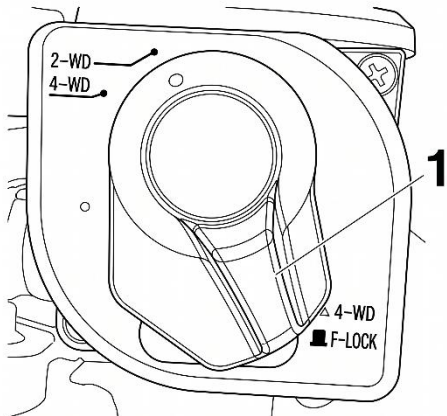

### 2-Wheel Drive (2WD) mode

Push selector 1 to the left to activate 2WD mode.

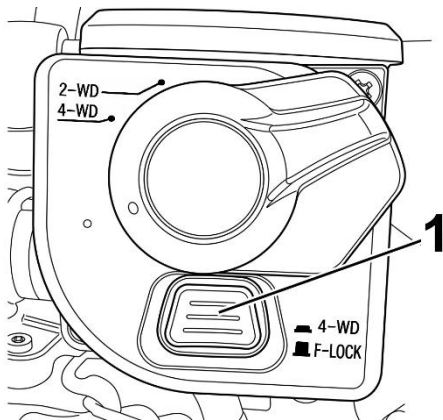

### 4-Wheel Drive (4WD) mode and front differential lock

Move selector further to the right to open front differential lock button 1.

Push the button 1 out to lock front differential. Push in to back to 4WD mode with differential unlocked.

NOTE: You will not be able to switch to 2WD mode with front differential locked – the selector protects to doing so. To back to 2WD mode push button 1 in to 4WD position and then move selector to the left to 2WD position mode.

### **(3) Mechanical parking brake**

The parking brake is located on the right-hand side. When the TRACTOR is switched off, move the lever on the handlebar next to the throttle control to the right (about 170°).

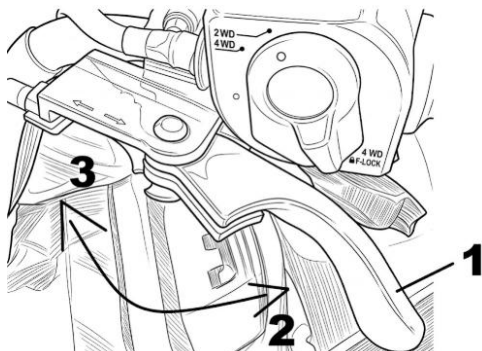

This will prevent you from accidentally operating the throttle lever. To restart, once the TRACTOR is on, release the handbrake lever bringing it to the left and then accelerate by pressing the throttle lever.

1. Mechanical parking brake handle

2. Parking brake applied

3. Parking brake released

NOTE: When parking your TRACTOR on an inclined road, you must use the parking brake or the TRACTOR may move freely and cause an accident to you or others.

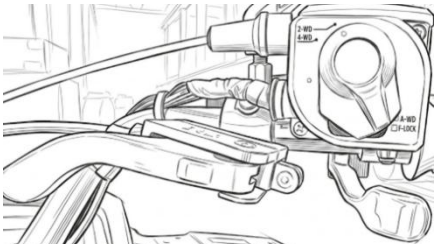

Parking brake released.

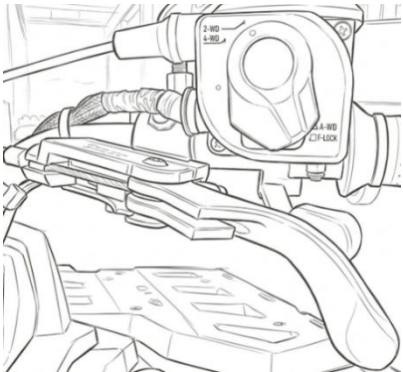

Parking brake applied.

**(4) Throttle lever**

The throttle lever is located on the right side of the handlebar.

When pushed forward, it increases the engine speed and allows engagement of the transmission on the selected range.

When released, the engine speed should automatically return to idle, and the TRACTOR will gradually slow down.

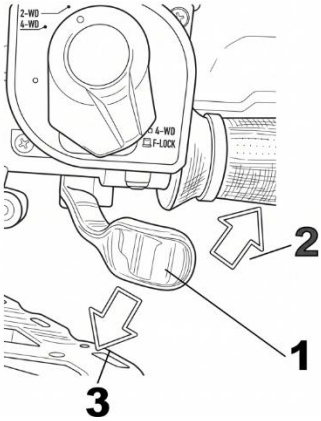

- 1. Throttle lever
- 2. Push throttle lever to accelerate
- 3. Release throttle lever to decelerate

**(5) Foot pegs**

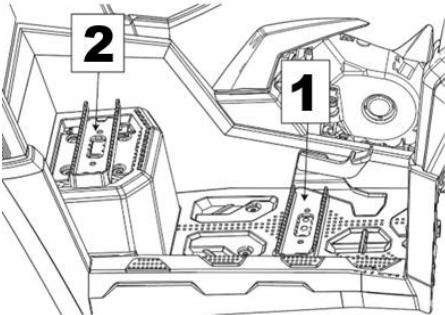

The toothed foot pegs are located on the left and right sides of the TRACTOR - near the engine.

The driver foot peg is marked 1.

The passenger foot peg is marked 2.

## **(6) Multi-function Switch – option 1**

The multi-function switch is located on the left side of the handlebar.

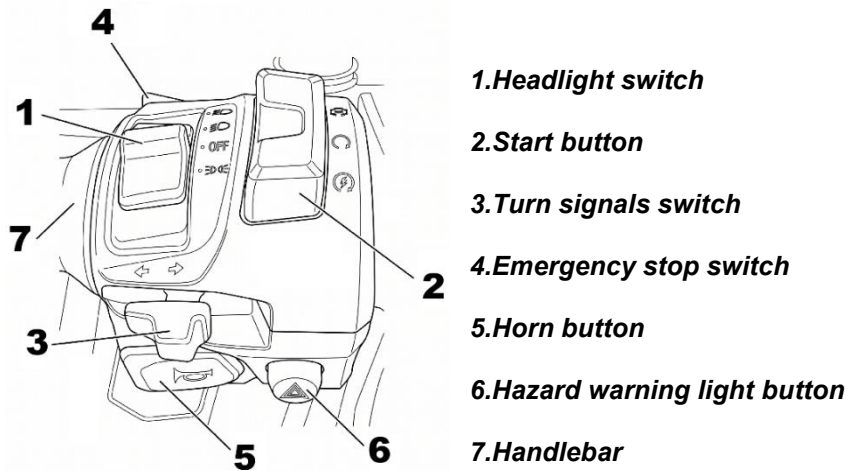

### **1) Headlight switch**

To activate the low beam headlight and the taillight set the switch to position:



To activate the high beam headlight set the switch to position:



### **2) Start button**

First confirm the gear shift lever is in P or N and emergency stop switch is in “RUN” position.

**When using Ignition key:** Turn the key to “ON” position, then press start button to start engine; release start button when engine starts.

**When using Tether key:** Put tether key on the knob, then press start button to start engine; release start button when engine starts.

**WARNING!** Always attach Tether key strap around your wrists before starting the engine.

To understand how the Tether key works refer to point “(25) Tether key”.

NOTE: When you press once the start button, without applying tether switch on the knob then all electrical circuits will activate. They will be shut down after few seconds.

- Do not operate the electric starter continuously for more than seconds, as the starter damage could occur. Wait at least 5 seconds between each operation of the electric starter to let it cool down.
- Do not press start button with the engine running, as damage to the electric starter can occur.

### **3) Turn signals switch**

The turn signal switch is located under the start button. Push the button to the left to activate the left blinker and push to the right activate the right blinker. To switch off turn signals push the switch to “0” position.

### **4) Emergency stop switch**

Press the emergency stop switch to stop the engine. Press the button again to restart the engine. This switch can be used to stop engine and as an emergency control.

NOTE: Do not turn on the key switch when the emergency stop switch is in “OFF”.

**(5) Horn Button** – Press the horn button to sound the horn.

**(6) Hazard warning light Button** – Use the hazard switch to warn others about emergency situation.

## **(6) Multi-function Switch – option 2 (ABS version)**

The multi-function switch is located on the left side of the handlebar.

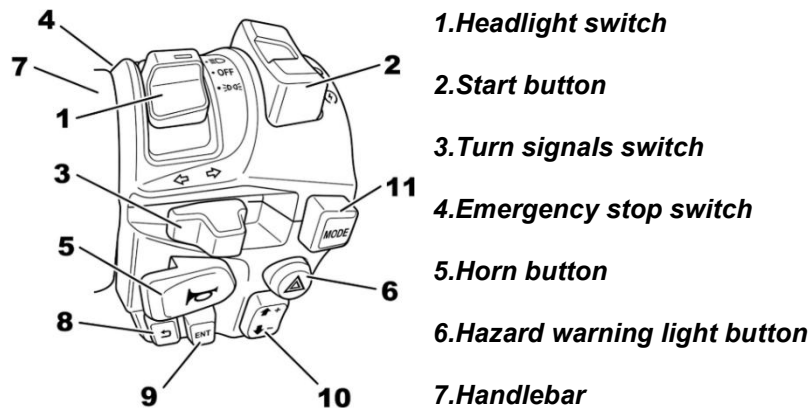

**ABS functions: 8. Return; 9. Enter; 10. Up – Down (speed limit); 11. Mode**

### **1) Headlight switch**

To activate the low beam headlight and the taillight set the switch to position:



To activate the high beam headlight set the switch to position:



### **2) Start button**

First confirm the gear shift lever is in P or N and emergency stop switch is in “RUN” position.

**When using Ignition key:** Turn the key to “ON” position, then press start button to start engine; release start button when engine starts.

**When using Tether key:** Put tether key on the knob, then press start button to start engine; release start button when engine starts.

**WARNING!** Always attach Tether key strap around your wrists before starting the engine.

To understand how the Tether key works refer to point “(25) Tether key”.

NOTE: When you press once the start button, without applying tether switch on the knob then all electrical circuits will activate. They will be shut down after few seconds.

- Do not operate the electric starter continuously for more than seconds, as the starter damage could occur. Wait at least 5 seconds between each operation of the electric starter to let it cool down.
- Do not press start button with the engine running, as damage to the electric starter can occur.

### **3) Turn signals switch**

The turn signal switch is located under the start button. Push the button to the left to activate the left blinker and push to the right activate the right blinker. To switch off turn signals push the switch to “0” position.

### **4) Emergency stop switch**

Press the emergency stop switch to stop the engine. Press the button again to restart the engine. This switch can be used to stop engine and as an emergency control. NOTE: Do not turn on the key switch when the emergency stop switch is in “OFF”.

**5) Horn Button** – Press the horn button to sound the horn.

**6) Hazard warning light Button** – Use the hazard switch to warn others about emergency situation.

**(7) Multi-function gauge – option 1 (touch screen)**

Gauge functions:

1. **Speedometer indicator**
2. **Engine speed indicator**
3. **Fuel level gauge**
4. **Engine coolant temperature indicator**
5. **Total odometer**
6. **Trip A odometer**
7. **Trip B odometer**
8. **Engine hours Trip A**
9. **Engine hours Trip B**
10. **Battery voltage warning light**
11. **Time**
12. **Gear position indicator**
13. **2WD/4WD and differential lock indicator**
14. **EPS warning light**
15. **Engine warning light**
16. **Oil pressure warning light**
17. **Light indicator**
18. **Trailer indicator light**
19. **Brake system warning light**
20. **Parking brake warning light**
21. **ABS indicator (when equipped)**
22. **Turn indicators**
23. **Alarms**
24. **MENU settings**

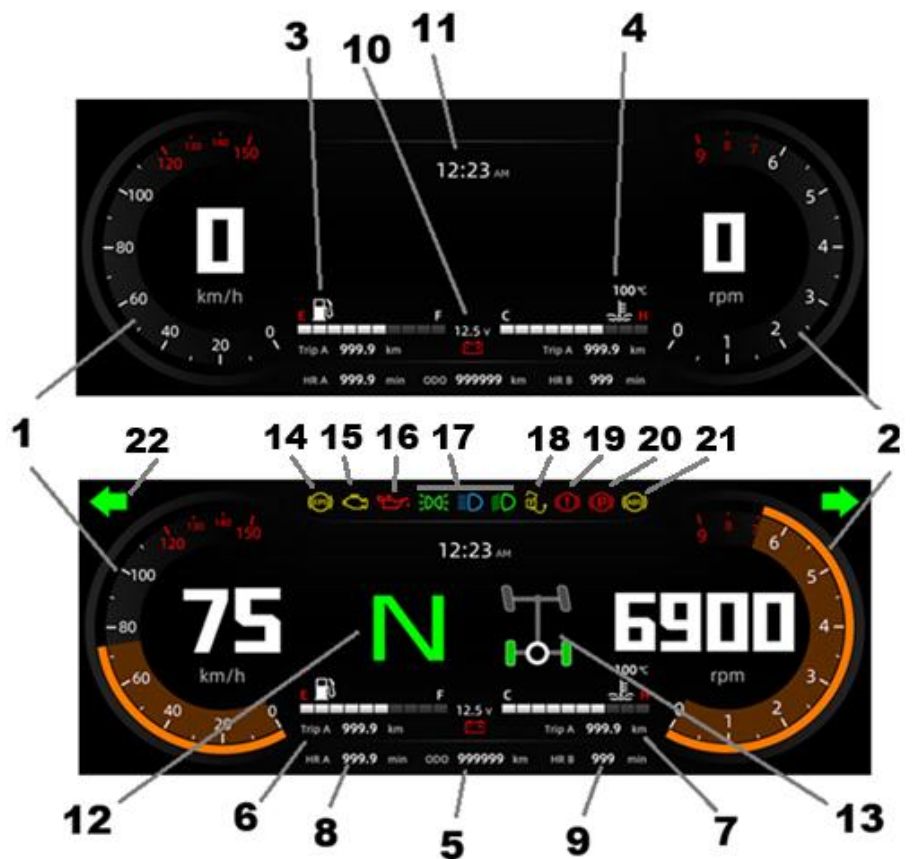

### 1) **Speedometer indicator**

The speed value will be displayed and updated synchronously while driving. Icon will change from KM/H to MPH whatever is selected.

### 2) **Engine speed indicator**

The speed value of the engine RPMs will be displayed and updated while engine throttle applied.

### 3) **Fuel level gauge**

The bars on the gauge have range from 1 to 10 bars according to fuel amount in the tank. When there are 10 bars it means that fuel tank is full. Bars will disappear when using fuel accordingly. When last bar lights on red and warning light will become yellow, indicating fuel reserve, stop as soon as possible to refuel.

*Example of full tank of gasoline:*



*Example of tank on reserve of gasoline:*



### 4) **Engine coolant temperature indicator**

The bars on the gauge have range from 1 to 10 bars on according. The bar amount will set according to coolant temperature.

The temperature of coolant is shown above the icon (example below):



When the coolant temperature is high ( $\geq 115^{\circ}\text{C}$ ), the red displays in red and it indicates that the engine is overheating (example below):



Turn the engine off. Check coolant and refill it if necessary. Contact an authorized dealer when this is repeated. Do not use the TRACTOR until it has been repaired.

### 5) **Total odometer**

It shows actual total kilometers driven by the TRACTOR.

### 6) **Trip A odometer**

Displays the trip mileage of the TRACTOR. Display range: 0~999.9 km. When it reaches the maximum displayed mileage of 999.9 km, it automatically resets to zero and starts accumulating again. Manual

Reset of "Trip A" mileage is supported by pressing and holding the "Trip A" area for 3 seconds to reset.

A black rectangular display showing the text "Trip A 999.9 km" in white.

#### 7) Trip B odometer

Displays the trip mileage of the TRACTOR. Display range: 0~999.9 km. When it reaches the maximum displayed mileage of 999.9 km, it automatically resets to zero and starts accumulating again. Manual Reset of "Trip B" mileage is supported by pressing and holding the "Trip B" area for 3 seconds to reset.

A black rectangular display showing the text "Trip B 999.9 km" in white.

#### 8) Engine hours Trip A

Displays the cumulative runtime after the TRACTOR's engine is started. Display range: 0~999 min. When it reaches the maximum displayed time of 999 min, it automatically resets to zero and starts accumulating again. Manual Reset of "HR A" Time: It is supported by pressing and holding the "HR A" area for 3 seconds to reset.

A black rectangular display showing the text "HR A 999 min" in white.

#### 9) Engine hours Trip B

Displays the single runtime after the TRACTOR's engine is started. Display range: 0~999 min. When it reaches the maximum displayed time of 999 min, it automatically resets to zero and starts accumulating again. The display resets to zero after each power-on. Manual Reset of "HR B" Time: It is supported by pressing and holding the "HR B" area for 3 seconds to reset.

A black rectangular display showing the text "HR B 999 min" in white.

#### 10) Battery voltage warning light

The Voltage value and indicator color will change according to the true voltage in the battery. If the indicator is on red, it means the voltage value is less than 12.3V. If the indicator is on in white, it means the voltage value is more than 12.3V.

#### 11) Time

#### 12) Gear position indicator

Displays the current gear of the TRACTOR's transmission.

A row of five colored boxes representing gear positions: L (green), H (green), N (green), R (yellow), and P (red).

### 13) 2WD/4WD and differential lock indicator

The indicator shows what system is activated on the TRACTOR. On the left side is description of each possible configuration of the system (NOTE: not all modes might be on the TRACTOR as indicated on the picture below).

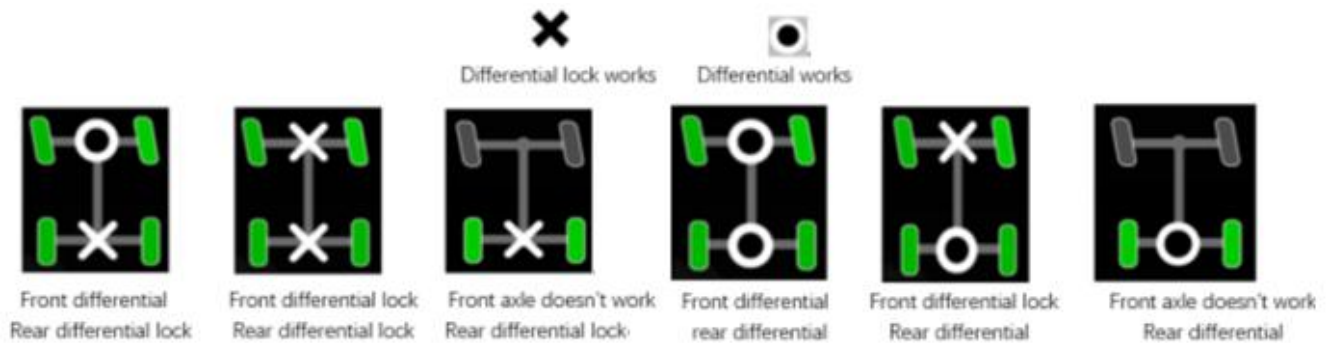

### 14) EPS warning light

When this light is on the EPS is not working. Contact an authorized dealer.

### 15) Engine warning light

After turning on the ignition switch, the light shall be on, and the light should turn off immediately after starting the engine. If the light is on while the engine is running, it indicates that the system has an error.

When some parts of the electric motor are defective, the check engine light will also be on, the TRACTOR can still be running, the driving performance may deteriorate, which indicates that the TRACTOR needs repairs.

### 16) Oil pressure warning light

When this warning lights ON, it indicates a low oil pressure.

**WARNING!** If the light does not turn off right after you start the engine, stop the engine immediately. Check engine oil level. Refill if necessary. If the oil level is good, see an authorized ANOTHER EUROPE TRACTOR dealer. Do not use the TRACTOR until it has been inspected and repaired

### 17) Light indicator

High beam lights:  ; Low beam lights: 

Position light: 

When the indicator light is ON, the headlight is turned on.

### 18) Trailer indicator light

When trailer electric connector is connected to Tractor socket the trailer indicator light is on.

### 19) Brake system warning light

When the brake fluid level drops below minimum, the brake system warning light will be on. Check the brake fluid level and fill it in when necessary. If the light is still on, contact an authorized dealer. Do not use the TRACTOR until it has been repaired.

### 20) Parking brake warning light

When the parking brake lever is applied the warning light is ON. When releasing the parking brake the light will be OFF.

21) **ABS indicator (when equipped)** – this function is available for the TRACTORs with ABS.

### 22) Turn indicators

The left or right indicators lights are activated when turn signal switch is ON. They are also automatically activated when park brake is not engaged and operator is not present at the seat. Both indicators are working when hazard switch is in ON position.

### 23) Alarms

Both indicators are activated when operator is not present on the seat and mechanical parking brake lever is not applied.



### 24) Menu Settings

Menu Entry and Exit: Tap on the designated area within the screen to display the menu settings options.



**Backlight:** Backlight adjustment modes and backlight brightness value settings. The backlight adjustment modes include: Manual / Automatic.



In automatic mode, there are 2 brightness levels: Bright and Dim. In manual mode, the brightness can be manually adjusted from 1-100, where 1 is the dimmest and 100 is the brightest. The backlight brightness values can be set and memorized separately for when the low beam headlights are turned on and when they are off.

**Tire Diameter:** Allows for setting the tire diameter option. Settings are memorized after adjustment.

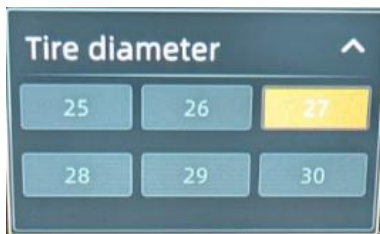

**EPS Mode:** Allows for setting the EPS mode option. Settings are memorized after adjustment.



**Clock:** Allows for setting and memorizing the clock mode (24-hour format, 12-hour format) and for adjusting the time.



**Units:** Allows for setting and memorizing metric and imperial units.



**Language:** Allows for setting and memorizing Italian, English, or other languages.

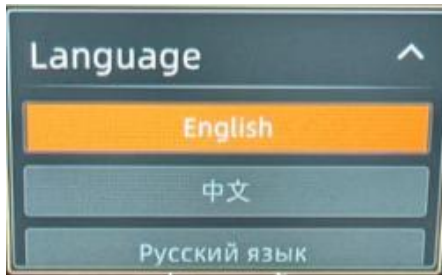

**Maintenance Information:** Displays the remaining distance to the next maintenance service. Initial maintenance reminder at 500km, followed by subsequent intervals of 2000km.



When the remaining maintenance mileage reaches 0km, a pop-up window will prompt for a reset operation. Clicking the "Yes" button will reset the maintenance mileage; clicking the "No" button will not reset the maintenance mileage (the pop-up window will be canceled), and the pop-up window will reappear after the system is powered on again.

**Fault Code:** Displays the fault code when the TRACTOR has a specific fault.

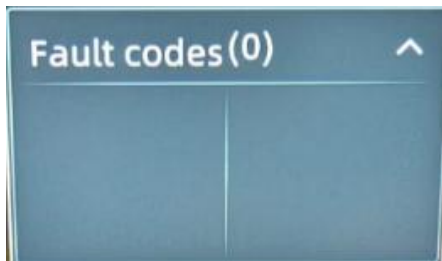

**TRACTOR Information:** Displays the total operating time since the TRACTOR was started.



**(7) Multifunction gauge – option 2 (touch screen)**

Gauge functions:

**1. Speedometer indicator**

**2. Engine speed indicator**

**3. Fuel level gauge**

**4. Engine coolant temperature indicator**

**5. Total odometer**

**6. Trip A odometer**

**7. Trip B odometer**

**8. Engine hours Trip A**

**9. Engine hours Trip B**

**10. Battery voltage warning light**

**11. Time**

**12. Gear position indicator**

**13. 2WD/4WD and differential lock indicator**

**14. EPS warning light**

**15. Engine warning light**

**16. Oil pressure warning light**

**17. Light indicator**

**18. Trailer indicator light**

**19. Brake system warning light**

**20. Parking brake warning light**

**21. ABS indicator (when equipped)**

**22. Turn indicators**

**23. Helmet connected indicator**

**24. Volume indicator**

**25. MENU settings**

**26. Speed limit indicator**

**27. Alarms**

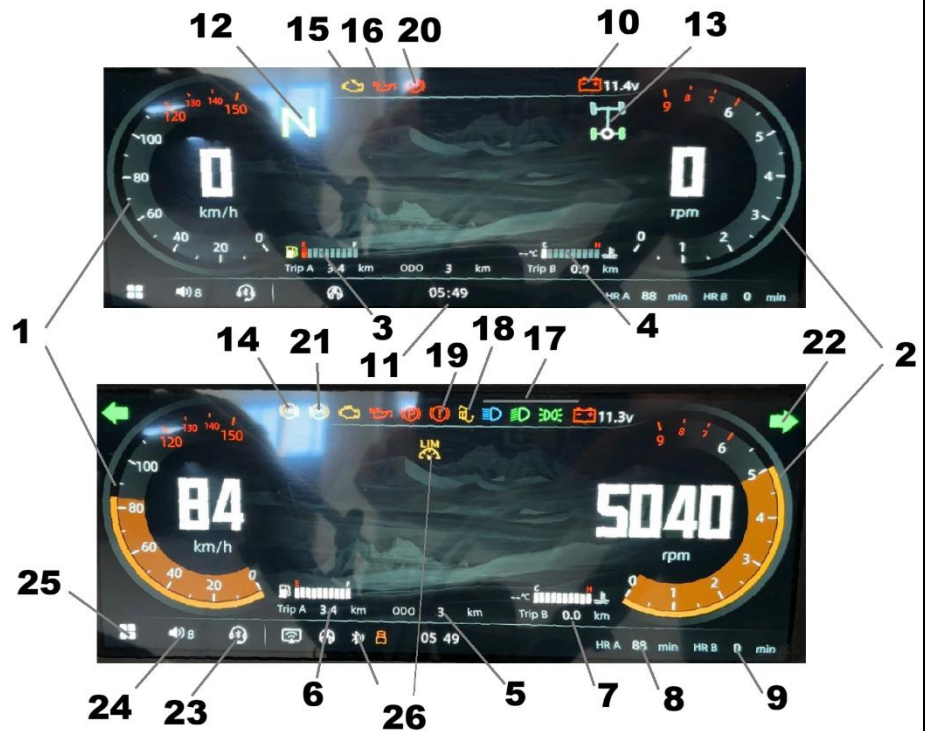

### 1) **Speedometer indicator**

The speed value will be displayed and updated synchronously while driving. Icon will change from KM/H to MPH whatever is selected.

### 2) **Engine speed indicator**

The speed value of the engine RPMs will be displayed and updated while engine throttle applied.

### 3) **Fuel level gauge**

The bars on the gauge have range from 1 to 10 bars according to fuel amount in the tank. When there are 10 bars it means that fuel tank is full. Bars will disappear when using fuel accordingly. When last bar lights on red and warning light will become yellow, indicating fuel reserve, stop as soon as possible to refuel.

*Example of full tank of gasoline:*



*Example of tank on reserve of gasoline:*



### 4) **Engine coolant temperature indicator**

The bars on the gauge have range from 1 to 10 bars on according. The bar amount will set according to coolant temperature.

The temperature of coolant is shown above the icon (example below):



When the coolant temperature is high ( $\geq 115^{\circ}\text{C}$ ), the red displays in red and it indicates that the engine is overheating (example below):



Turn the engine off. Check coolant and refill it if necessary. Contact an authorized dealer when this is repeated. Do not use the TRACTOR until it has been repaired.

### 5) **Total odometer**

It shows actual total kilometers driven by the TRACTOR.

### 6) Trip A odometer

Displays the trip mileage of the TRACTOR. Display range: 0~999.9 km. When it reaches the maximum displayed mileage of 999.9 km, it automatically resets to zero and starts accumulating again. Manual Reset of "Trip A" mileage is supported by pressing and holding the "Trip A" area for 3 seconds to reset.

A black rectangular display showing the text "Trip A 999.9 km" in white.

### 7) Trip B odometer

Displays the trip mileage of the TRACTOR. Display range: 0~999.9 km. When it reaches the maximum displayed mileage of 999.9 km, it automatically resets to zero and starts accumulating again. Manual Reset of "Trip B" mileage is supported by pressing and holding the "Trip B" area for 3 seconds to reset.

A black rectangular display showing the text "Trip B 999.9 km" in white.

### 8) Engine hours Trip A

Displays the cumulative runtime after the TRACTOR's engine is started. Display range: 0~999 min. When it reaches the maximum displayed time of 999 min, it automatically resets to zero and starts accumulating again. Manual Reset of "HR A" Time: It is supported by pressing and holding the "HR A" area for 3 seconds to reset.

A black rectangular display showing the text "HR A 999 min" in white.

### 9) Engine hours Trip B

Displays the single runtime after the TRACTOR's engine is started. Display range: 0~999 min. When it reaches the maximum displayed time of 999 min, it automatically resets to zero and starts accumulating again. The display resets to zero after each power-on. Manual Reset of "HR B" Time: It is supported by pressing and holding the "HR B" area for 3 seconds to reset.

A black rectangular display showing the text "HR B 999 min" in white.

### 10) Battery voltage warning light

The Voltage value and indicator color will change according to the true voltage in the battery. If the indicator is on red, it means the voltage value is less than 12.3V. If the indicator is on in white, it means the voltage value is more than 12.3V.

### 11) Time

### 12) Gear position indicator

Displays the current gear of the TRACTOR's transmission.

A display showing five gear positions: L (green), H (green), N (green), R (yellow), and P (red).

**13) 2WD/4WD and differential lock indicator**

The indicator shows what system is activated on the TRACTOR. On the left side is description of each possible configuration of the system (NOTE: not all modes might be on the TRACTOR as indicated on the picture below).

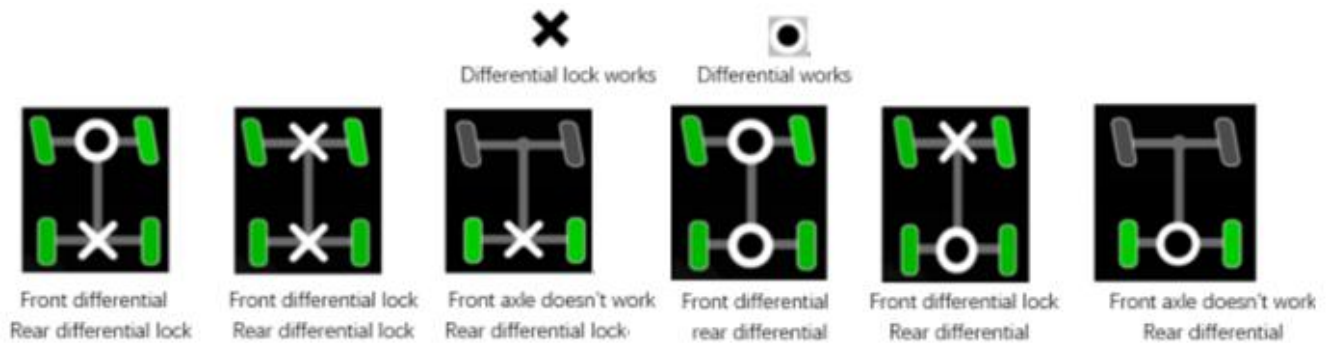

**14) EPS warning light**

When this light is on the EPS is not working. Contact an authorized dealer.

**15) Engine warning light**

After turning on the ignition switch, the light shall be on, and the light should turn off immediately after starting the engine. If the light is on while the engine is running, it indicates that the system has an error.

When some parts of the electric motor are defective, the check engine light will also be on, the TRACTOR can still be running, the driving performance may deteriorate, which indicates that the TRACTOR needs repairs.

**16) Oil pressure warning light**

When this warning lights ON, it indicates a low oil pressure.

**WARNING!** If the light does not turn off right after you start the engine, stop the engine immediately. Check engine oil level. Refill if necessary. If the oil level is good, see an authorized ANOTHER EUROPE TRACTOR dealer. Do not use the TRACTOR until it has been inspected and repaired

**17) Light indicator**

High beam lights:  ; Low beam lights: 

Position light: 

When the indicator light is ON, the headlight is turned on.

**18) Trailer indicator light**

When trailer electric connector is connected to Tractor socket the trailer indicator light is on.

**19) Brake system warning light**

When the brake fluid level drops below minimum, the brake system warning light will be on. Check the brake fluid level and fill it in when necessary. If the light is still on, contact an authorized dealer. Do not use the TRACTOR until it has been repaired.

### 20) Parking brake warning light

When the parking brake lever is applied the warning light is ON. When releasing the parking brake the light will be OFF.

21) **ABS indicator (when equipped)** – this function is available for the TRACTORS with ABS.

### 22) Turn indicators

The left or right indicators lights are activated when turn signal switch is ON. They are also automatically activated when park brake is not engaged and operator is not present at the seat. Both indicators are working when hazard switch is in ON position.

### 23) Helmet connected

When the helmet will be connected to the information system this icon will show up.

### 24) Volume

Touching the icon allows to adjust the volume of the media which appears in the middle of the display.

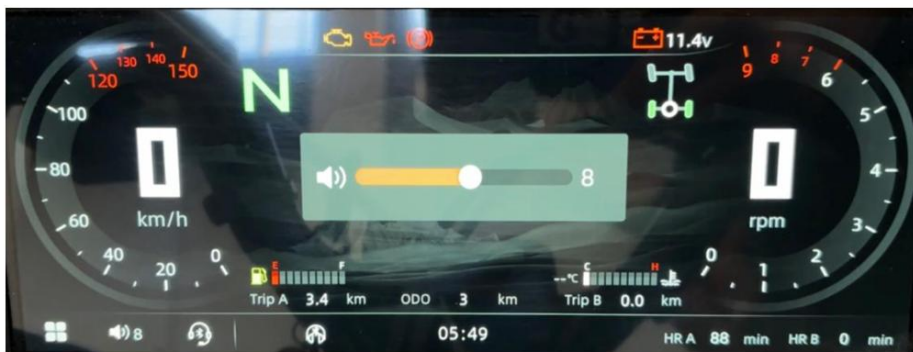

### 25) Menu information system

Menu Entry and Exit: Tap on the designated area within the screen to display the menu settings options.



Hidden Menu information system is located under the icon (located bottom/left corner of the display):



Tap on the designated area within the screen to display the menu settings options.

**Settings:** Allows to find the following settings:

- **Display:**
  - **Backlight:** Adjustment modes and backlight brightness value settings. The backlight adjustment modes include: Manual / Automatic. In automatic mode, there are 2 brightness levels: Bright and Dim. In manual mode, the brightness can be manually adjusted from 1-100, where 1 is the dimmest and 100 is the brightest. The backlight brightness values can be set and memorized separately for when the low beam headlights are turned on and when they are off.
  - **Clock:** Allows for setting and memorizing the clock mode (24-hour format, 12-hour format) and for adjusting the time.
  - **Units:** Allows for setting and memorizing metric and imperial units.
  - **Language:** Allows for setting and memorizing Italian, English, or other languages.
- **Bluetooth:**
  - **Cell phone:** Allows to find information about BT name, currently connected cell phone and available cell phones to connect
  - **Helmet:** Allows to find information about BT name, currently connected helmet and available helmets to connect
- **Media:** to adjust the volume of the media
- **System:**
  - **Ver.:** Displays the version of the system and be able to update it
  - **Fault codes:** Displays the fault code with its description.
  - **Travel:** Displays the:
    - **Vehicle information** regarding total engine running time
    - **Tire diameter** and allows for setting the tire diameter option (the settings are memorized after adjustment)
    - **EPS mode** and allows for setting the EPS mode option (settings are memorized after adjustment).
    - **Maintain** – maintenance mileage with remaining mileage to next maintenance. Initial maintenance reminder at 500km, followed by subsequent intervals of 2000km. Follow When the remaining maintenance mileage reaches 0km, a pop-up window will prompt for a reset operation. Clicking the "Yes" button will reset the maintenance mileage; clicking the "No" button will not reset the maintenance mileage (the pop-up window will be canceled), and the pop-up window will reappear after the system is powered on again.

**Media:** Allows to find Bluetooth media connected to the Menu information system.

**Phone:** Allows to find your connected phone information.

**Connection:** Allows to find the version of the display and QR code you can scan to connect to the Menu information system.

**26) Speed limit indicator** – (ABS function only) – indicate adjusted speed of TRACTROR

## 27) Alarms

Both indicators are activated when operator is not present on the seat and mechanical parking brake lever is not applied.



### **(8) Rear view mirror**

Installed to observe the traffic behind the TRACTOR through the rearview mirror.

### **(9) Rear storage**

Convenient location to carry personal articles.

**WARNING!** When engine is running, always engage the PARK position on the shift lever before opening cover. Never leave any heavy or loose breakable objects in the storage area. Always latch the cover before driving.

### **(10) License plate lamp**

The license plate light is always ON to illuminate the license plate.

### **(11) Trailer socket**

Electrical trailer socket provides power to the trailer lights. It is located on the rear side of the TRACTOR.

### **(12) Fender (If equipped)**

The fender is optional equipment; its function is to protect plastics of the TRACTOR and improve mud capture coming from wheels.

### **(13) Front Seat**

NOTE: to dismount front seat you have to dismount rear seat first.

#### **Dismounting the seat**

Push latch forward while gently lifting rear of front seat. Pull the seat backwards. Continue lifting until you can release the front retaining device, then completely remove the seat.

#### **Front seat Installation**

Insert the seat tabs into the frame hook. When the seat rests in place, push the seat down firmly to lock it.

NOTE: The driver seat is equipped with the pressure switch, be careful when removing or installing the seat to not damage the wiring and connector during removal or installation of the seat. Check if the buzzer of ignition warning rings, when the driver leaves the seat and does not apply park brake.

### **(14) Gear lever**

The shift lever is located on the right side of the TRACTOR near steering column.

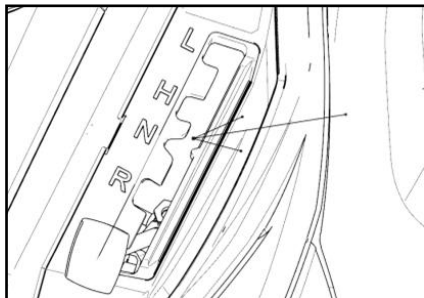

**WARNING!** To shift gears: Stop the TRACTOR completely., leave the engine idling and then move the lever to the desired position. Do not force lever. If you cannot shift the gears, gently operate the throttle and release it immediately, then wait for the engine speed to return to stable and try again.

**CAUTION:** Always come to complete stop of the TRACTOR and apply the brake before operating the gear lever.

**P: Park**

This position locks the transmission to prevent the TRACTOR from moving. Always use it when the TRACTOR is not in operation. In some circumstances ,it may be necessary to rock the TRACTOR back and forth to move the gears in the transmission to allow the park to be engaged.

**R: Reverse**

This allows the TRACTOR to go backward. The speed of the TRACTOR is limited.

**N: Neutral**

This position disengages the transmission to allow manual movement of the TRACTOR.

**H: High gear**

This selects the high-speed range of the transmission in the gearbox. It is the normal driving speed range. It allows the TRACTOR to reach its maximum speed.

**L: Low gear**

This selects the low-speed range of the transmission in the gear box. It is the work position. It allows the TRACTOR to move slowly with the maximum traction and power.

NOTE: Use the low-speed range to pull, tow any load or to climb a steep incline.

**(15) Front/Rear Bumper**

The front and rear side bumpers are optional equipment of the TRACTOR.

**(16) Headlight / Turn indicators/ Hazard warning light**

The low beam is used for close-up illumination.

The high beam can improve visibility and expand the field of view on a greater distance.

The turn signal is a warning light that comes on when is activated from multi-functional switch to indicate turning direction and warn other TRACTORS or pedestrians about emergency when using hazard switch.

NOTE: Remember that having the lights on without the engine running discharges the battery. Always turn take out Tether key after engine has been stopped.

**(17) Towing hook / Winch**

The front towing hook for winching the TRACTOR is located at the end of the cord.

The winch can be operated using the winch control switch located near the multi-functional switch.

NOTE: Intensive use of the winch for a long period of time may drain the battery.

The following tips will help to reduce the risk of discharging the battery:

Always unwind manually: Unlock the cord using the handle then pull on the hook strap to unwind.

It is recommended to keep your TRACTOR running while using the winch. Do not stop the TRACTOR immediately after using the winch to allow the battery to charge.

In addition, when using the winch for more than 30 seconds, it is recommended to increase engine RPM in the range of 3000 RPM to increase charging power of the battery.

NOTE: Make sure TRACTOR is in NEUTRAL (N) before increasing engine RPM.

Refer to *“The Assembly & Operating Instructions”* manual for more information about the winch.

To power the TRACTOR without starting the engine, refer to the ELECTRICAL SYSTEM.

### **(18) Brake Lever**

When the brake lever is pressed the front and rear brakes are applied.

When released the brake lever should automatically return to its original position.

Braking effect is proportional to the force applied on the lever.

NOTE: As with other wheeled TRACTORS the weight of the TRACTOR is transferred to the front wheels during braking. To achieve greater stopping efficiency, the brake system distributes more braking force to the front wheels. This will affect TRACTOR handling and steering control when braking vigorously. Take it into account when braking.

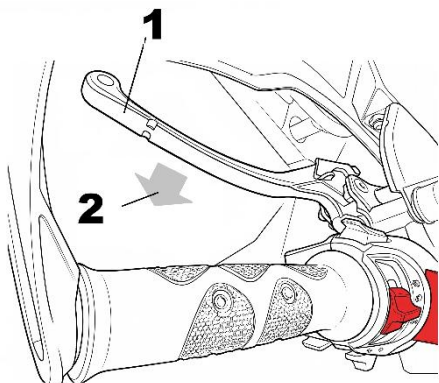

1. Brake lever
2. To apply brakes

### **Brake lock lever on brake lever (option)**

The brake lock lever is located on the LH brake lever. Engage the brake lock whenever the TRACTOR is parking.

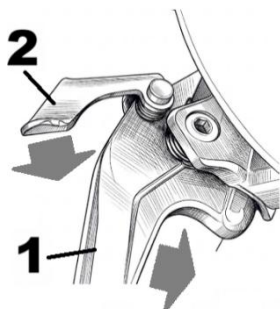

1. Squeeze the brake lever.
2. Move the brake lock lever forward

To unlock squeeze the brake lever and lock will be released automatically

### **(19) Rear seat**

#### **Dismounting the seat**

Pull red strap located in the middle of the rear seat to lift seat. Pull the seat forward. Continue lifting until you can release the front retaining device, then completely remove the seat.

#### **Seat Installation**

Insert the seat tabs into the frame hook. When the seat rests in place, push the seat down firmly to lock it. Check if is the seat is locked before driving the TRACTOR.

### **(20) Towing hitch**

Towing trailer hitch is assembled on the TRACTOR to pull a trailer.

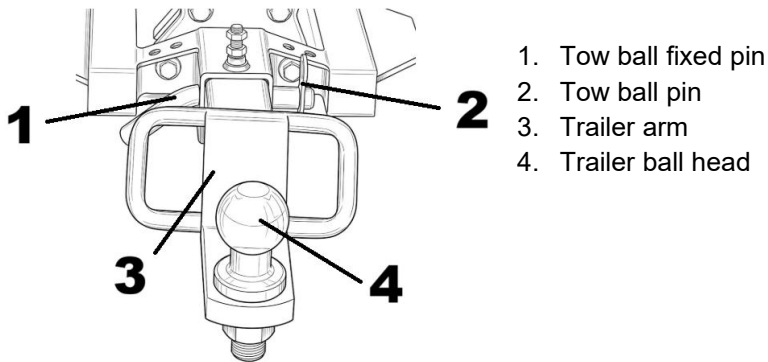

### **(21) Tail/brake lights**

The color of position tailings and brake light are red. The taillights and turn indicators are activated from multi-functional switch. The red brake lights are activated when braking by brake pedal or brake lever.

### **(22) Rear reflectors**

The red reflectors are located at the rear of the TRACTOR. They improve visibility of the TRACTOR.

### **(23) Cargo rack**

The front/rear cargo racks are located on the front/rear plastic cover. They are to help you to carry equipment and various other cargo. Never carry a passenger on the rack.

### **(24) Electrical heating handlebar grip (If equipped)**

Electrical heating handlebar grip is optioned equipment on the TRACTOR. Its function is to warm up the handlebar grips.

### **(25) Ignition switch / Tether key**

The ignition switch is located on the console under the right handlebar. The functions of the respective switch positions are as follows:

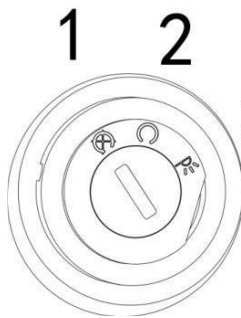

1. OFF: All electrical circuit lights are OFF. The key can be removed from its position.

2. ON / ACC: Turn the engine ON position. All electrical circuits are powered, electronic fuel injection system ready, 2WD/4WD modes ready, instrument will illuminate. The TRACTOR is ready to start the engine

NOTE: Remember that having the lights on without the engine running discharges the battery. Always turn ignition to OFF after engine has been stopped.

**If your TRACTOR is equipped with Tether key 1 then familiarize with the following:**

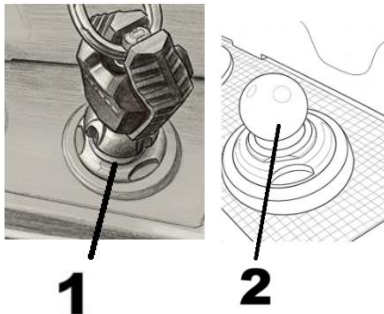

The tether key 1 is significant element to start your engine.

The tether key is your secure key for your TRACTOR that automatically shut down the engine when the tether key is separated from the tether knob 2.

Apply the tether key on the knob and be able to start the engine with the start button.

### **(26) Auxiliary DC socket**



The auxiliary DC socket is located on left side of the front panel. This socket can be used for suitable portable players. Use the DC outlet socket only when the engine is running.

Maximum rated capacity for auxiliary DC outlet: DC 12V, 120W (10A)

NOTE: cover the socket back with the cap when it is not in use.

#### **CAUTION:**

- Do not use accessories that require more than the above stated maximum capacity. Doing so may overload the circuit and cause the fuse blowing.
- If accessories are used without the engine running or with the headlights on, the battery will lose its charge and starting the engine may become difficult.
- Do not use a car cigarette lighter or other accessories with a plug that gets hot.

**(27) USB port**

This port is a serial bus standard for external devices with input and output interfaces like USB or type-C port.

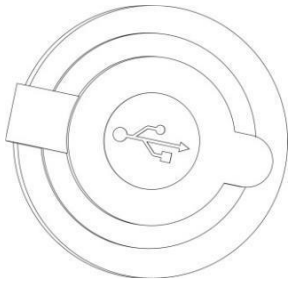

**(29) Handlebar cover**

Optional accessory mounted on handlebar to protect the hands and handlebar from damaging them.

**(30) Tool kits**

The tool kits contain basic tools for repair the TRACTOR and its maintenance.

## FUEL

### Fuel Requirements

NOTE: Always use fresh gasoline. Gasoline will oxidize over time. The result is loss of octane, volatile compounds, and the production of rubber and paint deposits which can damage the fuel system.

Ethylene fuel blending varies by country and region. Always use recommended fuel – see RECOMMENDED FUEL chapter for details.

Inspect frequently for the fuel leaks or system abnormalities.

Alcohol blended fuels attract old moisture which may lead to fuel phase separation and can result in engine performance problems or engine damage.

### RECOMMENDED FUEL

Use e Petrol E5 / E10 with minimum octane rating of 92.

NOTE: Never experiment with other fuels. Using inappropriate fuel can cause damage to the engine or fuel system.

### FUELING PROCEDURE

**WARNING!** Fuel is flammable and explosive under certain condition. Never use an open flame to check fuel level. Never smoke or allow a flame or spark in the vicinity. Always work in a well-ventilated area.

NOTE: Always clean the surroundings of the fuel cap of any debris, dust, sand to avoid contaminating the fuel.

1. Stop the engine

**WARNING!** Always stop engine before refueling.

2. Do not allow anyone to remain seated on the TRACTOR while fueling.
3. Slowly unscrew fuel tank cap counterclockwise to remove it.

**WARNING!** If a differential pressure condition exists (whistling sound occurs when the fuel cap is loosened) have the TRACTOR inspected and/or serviced before further operation.

4. Insert the spout in the filler neck.
5. Pour fuel slowly to allow time for the air in the tank to escape and prevent fuel flow backflowing. Be careful not to spill the fuel.
6. Stop refueling when the fuel reaches the bottom of filler neck. Do not overfill.

**WARNING!** Always wipe off any fuel spillage from the TRACTOR

7. Fully tighten fuel tank cap clockwise.

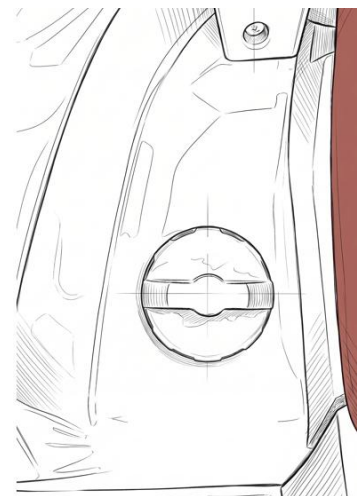

## TIRES

### POTENTIAL HAZARD

Using this TRACTOR with improper tires or with uneven tire pressure.

### WHAT CAN HAPPEN

Using improper tires on this TRACTOR or operating this TRACTOR with improper or uneven tire pressure, may cause loss of control increasing the risk of an accident.

### HOW TO AVOID THE HAZARD

1. The tires indicated in the certificate of conformity have been approved for this model. Other tire combinations are not recommended.
2. The tires should be set to the recommended pressure in TECHNICAL SPECIFICATION table.
3. Check and adjust tire pressures when the tires are cold. Tire pressure below the specified minimum pressure could cause the tire to bead off the rim in difficult driving conditions.
4. Higher pressures may cause the tire to burst. Inflate the tires very slowly and carefully. Fast inflation could cause the tire to burst.

### How to measure the tire pressure

Use the tire pressure gauge.

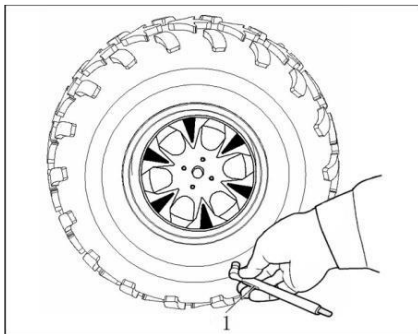

1 - Tire pressure gauge

NOTE: The tire pressure gauge is not included as standard equipment. Make two measurements of the tire pressure and use the second reading. Dust or dirt in the gauge could cause the first reading to be incorrect.

Set pressure with cold tires. Set tire pressures to the recommendation in TECHNICAL SPECIFICATION table.

### Tire wear limit

When the tire groove decreases to 6 mm due to wear, replace the tire.

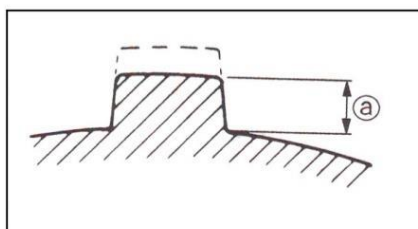

a - Tire wear limit

## BREAK-IN PERIOD

### Operation During Break-In

A break-in period of 10 operating hours or 300 km is required for the TRACTOR.

### Engine

During the break-in period:

- Avoid full throttle operation.
- The maximum throttle should not exceed 3/4.
- Avoid prolonged accelerations.
- Avoid prolonged cruising speeds.
- Avoid overheating the engine.

### Brakes

**WARNING!** New brakes will work efficiently after the break-in is completed after a period of about 50km.

### Drive Belt

The new belt requires a break in period of 50 km.

## BASIC PROCEDURES

### STARTING THE ENGINE

1. To start the engine, the gear lever must be set to PARK or NEUTRAL.

NOTE: For your convenience, an overdrive mode allows you to start the engine with the shift lever in any position. Press and hold the brake lever(s) or the brake pedal while pressing the engine start button.

2. Insert the key into the ignition switch and turn it to ON position or apply the Tether key on the knob.

**WARNING!** When using the tether key always attach Tether key strap around your wrists before starting the engine.

3. Press the engine start button and hold until the engine starts.

NOTE:

- If engine does not start after a few seconds, do not hold the engine start button for more than 10 seconds.
  - Check if fuel tank is empty, if so, refill it.
  - Contact an authorized dealer for help.
4. Immediately release the engine start button when the engine has started.

NOTE: When the battery is low, engine cannot be started. Have the battery recharged or replaced.

### CHANGING GEAR SELECTION

NOTE: It is necessary to always stop completely the TRACTOR and apply the brakes before moving the shift lever. Engine must be running at idle speed. Failure to do so may result in damage to the transmission.

To change gears, move the gear lever to desired position H, L, N, R, P.

### STOPPING THE ENGINE

NOTE:

- Avoid parking on slope as the TRACTOR may unintentionally move.
- Always put the TRACTOR in PARK when stationary or the Tractor parked to prevent rolling.
- Avoid parking in places where hot parts can cause a fire.

1. Release throttle to allow the engine to idle.
2. Set shift lever in PARK position. Apply the parking brake.
3. Push the emergency engine stop switch to OFF position.
4. Turn the key in the ignition switch to OFF position or use the TRACTOR emergency stop switch to stop the TRACTOR.

## ENGINE OVERHEAT

If engine overheats, try the following:

1. Check and clean radiator fins.
2. Check coolant level and refill if possible
3. Contact an authorized dealer as soon as possible.

**WARNING!** The radiator can be very hot, wear gloves before touching radiator.

**CAUTION:** Reduce the speed of the TRACTOR but try to keep it moving to supply air to radiator. If engine continues to overheat after approximately one minute, stop TRACTOR and set transmission to PARK. Stop engine. Turn the ignition switch to ON position (DO NOT RESTART ENGINE YET). The radiator fan will cool the radiator. Allow the engine to cool down. Check the coolant level and refill if possible.

**WARNING!** Never refill cooling system when engine is hot.

## POST-OPERATION CARE

When TRACTOR is used in saltwater environments (beach, boat launching/loading etc.), the TRACTOR must be rinsed with fresh water to preserve TRACTOR and its components. Lubrication of metal parts is highly recommended. This operation must be carried out at the end of each operating day.

When TRACTOR is used in muddy conditions, it is recommended that the TRACTOR must be rinsed to preserve TRACTOR and its components and to keep lights clean.

**NOTE:** Never use the high-pressure washer to clean the TRACTOR. USE LOW PRESSURE ONLY (such as a garden hose). The high pressure can cause electrical or mechanical damages.

## STORAGE

When a TRACTOR is not in use for more than one month, proper storage is required. Carry out maintenance on the key parts according to MAINTENANCE CHART.

## TRANSPORTING

Follow these procedures when transporting the TRACTOR:

- Turn off the engine and remove the key (if applicable remove tether key from tether knob) to prevent loss during transporting.
- Ensure the fuel cap is installed correctly and secure.
- Ensure the seat(s) is (are) installed correctly and secure.
- Place the shift lever into any position except the parking position, apply park brake and to prevent the TRACTOR from moving.
- Block and secure both the front and rear of the TRACTOR frame to the transporting device. This will prevent the TRACTOR from sliding or moving during transport.

## SPECIAL PROCEDURES

### WHAT TO DO IF WATER IS IN THE CVT

The CVT drain plug is located on the rear portion of the CVT cover. It is accessible from the rear left fender. Inspect the CVT drain plug to validate if water is present.

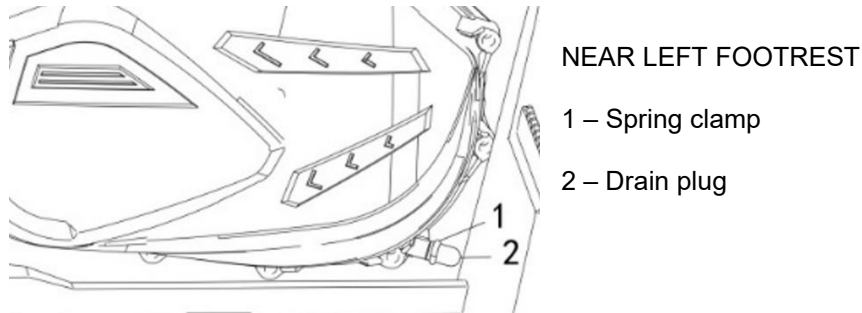

**NOTE:** If water entered your CVT, limit TRACTOR usage and take your TRACTOR to your nearest authorized dealer for a proper CVT cleaning procedure.

If water is present, remove CVT spring clamp and drain plug to expel water. Reinstall the drain plug and secure it using the spring clamp.

**NOTE:** Make sure that both spring clamp and drain plug are properly inserted on CVT cover tube.

### WHAT TO DO IF WATER IS IN THE AIR FILTER HOUSING

Inspect the drain tubes at the front left wheel inner fender for the water. If water is present, press clamps and remove drain tubes to drain water from air filter housing. Clean air filter housing, drain the reservoir.

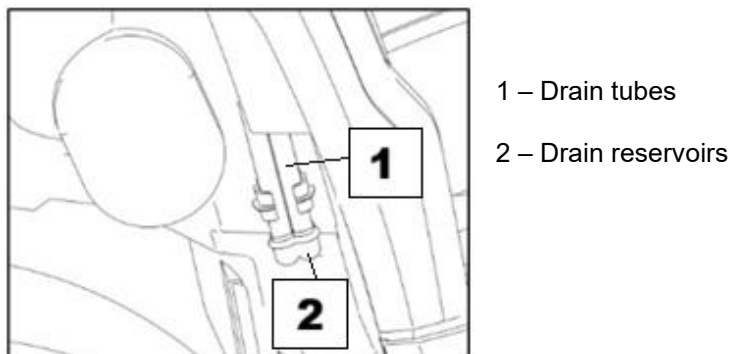

If during the inspection the following happens:

- If more than 50 ml of water is found in the drain hose.
- If any deposits are present in the clean chamber drain reservoir.
- If hose is obstructed.

Take the TRACTOR to your nearest authorized TRACTOR dealer to have the TRACTOR serviced.

In such a case, the TRACTOR must be serviced for:

- Cleaning of the air filter housing.
- Air vents (radiator cooling fan, water pump, coolant reservoir, fuel tank, gearbox, front differential and rear final drive)

- CVT air filter cleaning
- CVT cleaning
- Inspection and replacement of lubricants as needed (engine, gearbox, front differential and rear final drive).

NOTE: Failure to maintain the TRACTOR may result in permanent damage to the following components but not limited to:

- Engine and gearbox
- Fuel pump
- CVT
- Cooling fan
- Front differential
- Rear final drive

#### WHAT TO DO WHEN TRACTOR IS TURNED OVER

When the TRACTOR rolls over or is tilted on the side, put the TRACTOR back on its wheels. Inspect TRACTOR for damages.

If TRACTOR has no damage, refer to MAINTENANCE section and inspect the following.

- Inspect air filter housing for oil buildup, if any oil is found, clean air filter and air filter housing.
- Check engine oil level and refill in necessary.
- Check engine coolant level and refill if necessary.
- Check gearbox oil level and refill if necessary
- Check rear final drive oil level and refill if necessary.
- Check front differential level and refill if necessary.

Whenever the TRACTOR is tipped over, it must be inspected by an authorized dealer.

#### WHAT TO DO WHEN TRACTOR IS IMMERSED IN WATER

If the TRACTOR bis submerged, stop the engine immediately. Do not use:

- Any electrical equipment
- Winch

NOTE: Submersion of the TRACTOR can cause serious damage if the proper restart procedure is not followed.

As soon as TRACTOR is removed from the water, perform the following steps:

- Drain air filter housing. See procedure in this subsection.
- Drain CVT. See procedure in this subsection.

NOTE: The TRACTOR maintenance service should be performed as soon as possible by an authorized dealer.

## MAINTENANCE PROCEDURES

This section contains instructions for basic maintenance procedures.

**WARNING!** Stop the engine and follow these maintenance procedures when performing maintenance. If you do not follow proper maintenance procedures you may be injured by hot parts, moving parts, electricity, chemicals or other hazards.

**WARNING!** After removing the existing locking device, always replace it with a new one. (e.g. lock tab self-locking fastener, etc.).

### AIR FILTER

#### Air Filter Maintenance Guideline

As with any TRACTOR, air filter maintenance is critical to ensure proper engine performance and life span.

Air filter maintenance should be adjusted according to driving conditions.

The frequency of air filter maintenance should be increased when you are operating in following conditions:

- Driving on sandy terrain.
- Driving on dry dirt and dirty surfaces.
- Driving on dry gravel roads or similar conditions.

### AIR FILTER REMOVAL

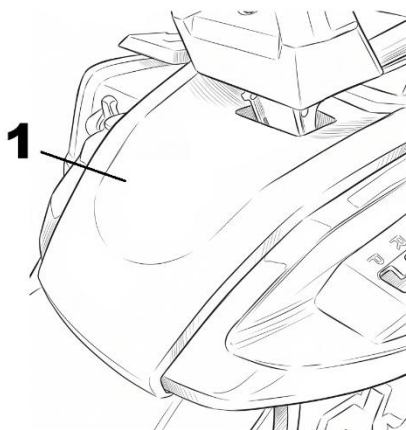

Remove seat. Remove air filter service cover.

1 - Air filter service cover

Remove air filter cover. Take out air filter.

## AIR FILTER CLEANING AND OILING

**CAUTION:** Always wear appropriate skin and eye protection. Chemicals can cause a skin rash and eye injury.

### Cleaning the paper filter:

- Make sure the foam filter element has been removed from the paper filter.
- Wipe off heavy dust from the paper element.

This will allow dirt and dust to get out of the paper filter.

NOTE: Paper filters have a limited lifespan; replace filter if too dirty or clogged.

NOTE: It is not recommended to blow compressed air on the paper filter: this could damage the paper fibers and reduce its filtration ability when used in dusty environments.

NOTE: Do not wash the paper filters with any cleaning solution.

### Cleaning the foam filter element

- Spray the foam filter element inside and out with a good air filter cleaner and follow manufacturer's instructions.
- Dry the foam element completely.

## AIR FILTER INSTALLATION

Insert the filter element and filter element cover back into the air filter and then insert the console back in place.

## MAINTENANCE OF CVT INTAKE PIPE

Remove seat. Remove air filter service cover.

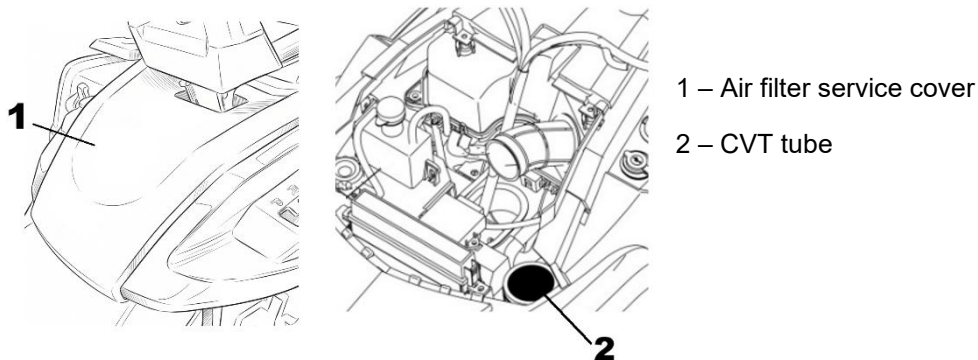

**CAUTION:** Always wear appropriate skin and eye protection. Chemicals can cause a skin rash and eye injury. Operation work needs to be in open area.

1. Clean the air intake pipe 2 using air pressure, wipe off the rest of the dust from the intake pipe.

**CAUTION:** Do not clean the air intake pipe against the wind, otherwise all dust will enter into eyes and mouth easily.

2. Assembly all the parts back in reversal order of the removal.

## LIFTING JACK POSITION / WHEELS REMOVAL

**To lift the TRACTOR with lifting jack, do the following:**

1. Park the Tractor on flat, level surface
2. Make sure the Tractor is in PARK and remove the key
3. Put the lifting jack under the bottom of the Tractor according to the lifting points marked on the TRACTOR
4. Loosen the wheel and lug nuts before the TRACTOR is off the ground, but do not remove
5. Safely lift on the lifting jack.
6. Remove the wheel lug nuts
7. Remove the wheel

**To remove lifting jack from lifted TRACTOR, do the following:**

1. Place the wheel in the correct position on the wheel hub.
2. Attach the wheel nuts and finger tighten.
3. Carefully lower the TRACTOR to the ground.
4. Torque the wheel nuts according to the specification.
5. Remove the lifting jack from the bottom of the TRACTOR

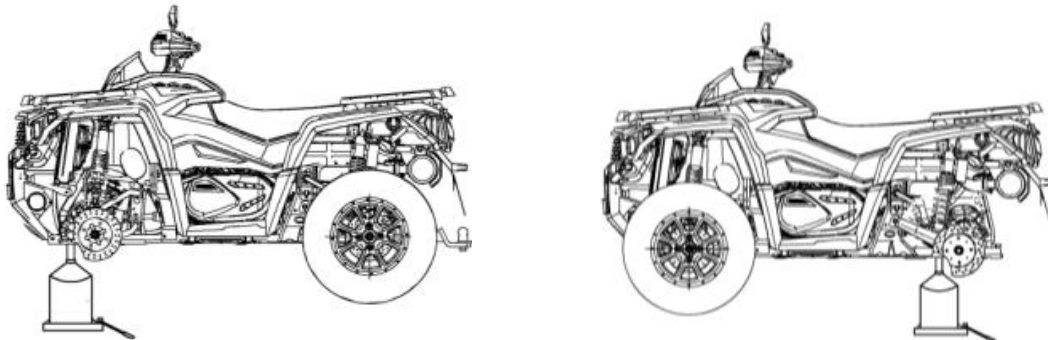

NOTE: Use the same procedure to lift front or rear side of the TRACTOR.

**WARNING!** Improperly installed wheels can adversely affect tire wear and TRACTOR handling, which can result in serious injury or death. Always ensure that all nuts are torqued to specification.

## GREASING POINT

The greasing point is located at the right side of the foot pedal – 1.

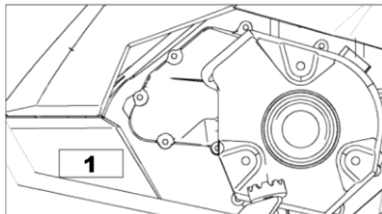

The greasing points are also located on the suspension a-arms. Grease according to TECHNICAL SPECIFICATION table.

## ENGINE OIL

### Engine Oil Level

Change the engine oil according to TECHNICAL SPECIFICATION table.

The engine oil capacity – refer to TECHNICAL SPECIFICATION table.

NOTE: Check level frequently and refill if necessary. Do not overfill. Operating the engine/gearbox with an improper level may severely damage engine/gearbox. Wipe off any spillage.

NOTE: While checking the oil level, visually inspect engine area for leaks.

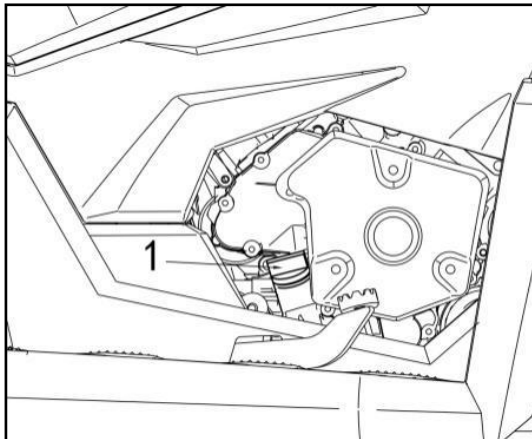

RIGHT SIDE OF ENGINE

1 - Dipstick

NOTE: Ensure the TRACTOR on a level surface and engine cold, not running, before checking the oil level.

#### To check the oil level:

1. Unscrew dipstick then remove it and wipe clean.
2. Reinstall dipstick, screw in it completely.
3. Remove and check oil level. It should be near or equal to the upper mark.

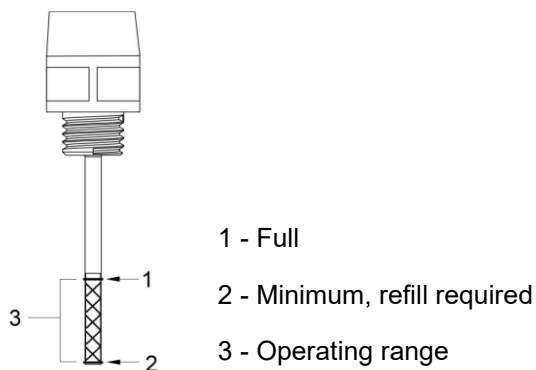

#### To add oil:

1. Remove the dipstick.
2. Place a funnel into the dipstick tube to avoid spillage.
3. Add a small amount of recommended oil and recheck oil level.
4. Repeat the above procedures until oil level reaches the dipstick's upper mark.

**Do not overfill.**

5. Properly tighten dipstick.

## OIL CHANGE AND OIL FILTER

**NOTE:** The oil and oil filter are to be replaced at the same time. The oil change should be done with a warm engine.

**WARNING!** The engine oil can be very hot. In order to avoid potential burns, do not remove the engine drain plug or the filter cover if the engine is hot. Wait until engine oil is warm.

1. Ensure TRACTOR is on a level surface.
2. Remove dipstick.
3. Clean the oil drain plug area.
4. Place a drain pan under the oil drainplug area.
5. Unscrew oil drain plug.

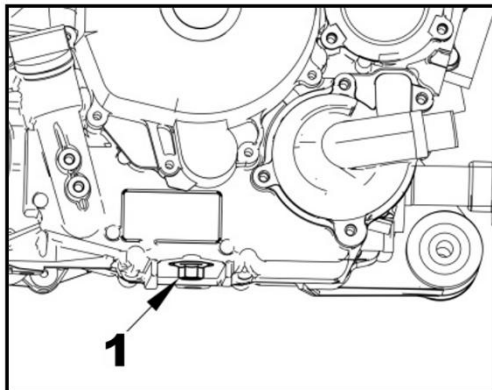

1 - Oil drain plug

**NOTE:** Wait for the oil to drain out of the oil filter.

6. Unscrew the oil filter cover.

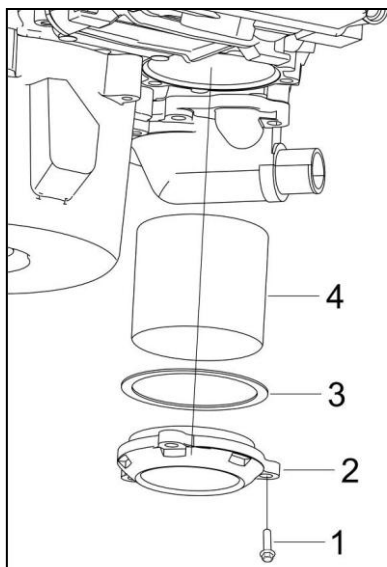

- 1 - Oil filter screw
- 2 - Oil filter cover
- 3 - Ring
- 4 - Oil filter

7. Remove the old filter and replace it with the new oil filter.
8. Check the O-ring cover and change it if necessary.
9. Screw in the oil filter cover in place.
10. Wipe out any oil spillage on the engine.
11. Change the washer on oil drain plug. Clean area on engine and the oil drain plug then re-install plug.

12. Refill engine at proper level with the recommended oil. Refer to TECHNICAL SPECIFICATIONS table.
13. Start engine and let it idle for a few minutes. Ensure oil filter area and oil drain plug areas are not leaking.
14. Stop engine. Wait a while to allow oil to flow down to the crankcase then check oil level. Refill as necessary.
15. Dispose of oil as per your local environmental regulations.

## ENGINE COOLANT

### Engine Coolant Level

**WARNING!** Check coolant level with engine cold. Never add coolant in cooling system when engine is hot.

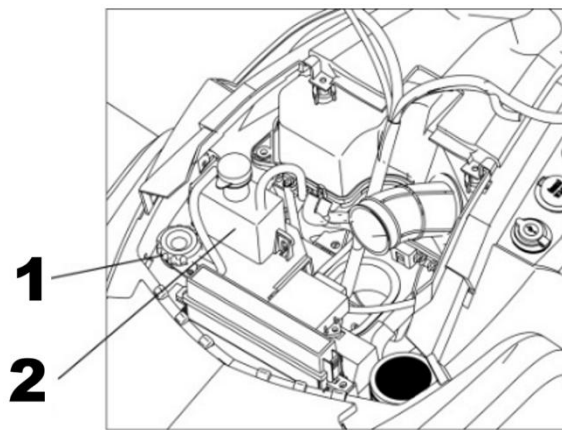

- 1 – Radiator cap
- 2 – Engine coolant reservoir

1. Place the TRACTOR on a level surface.
2. Remove the radiator cap by applying pressure and turning it counterclockwise.
3. Then drain the antifreeze from the engine.
4. Complete filling the radiator.
5. Check the level in the coolant reservoir and refill if necessary
6. Run engine at idle with the radiator cap off.
7. Slowly add coolant if necessary. At this point, wait until engine reaches normal operating temperature.
8. The liquid should be between MIN. and MAX. level marks of coolant reservoir.

NOTE: When checking level at temperature lower than 20°C, it may be slightly lower than MIN. mark.

NOTE: Ensure coolant reservoir hose is properly routed to avoid any interference when closing cover.

## GEARBOX FLUID REPLACEMENT

Prior to change the gearbox fluid, ensure TRACTOR is on a level surface. This operation should be done with a warm engine.

1. Ensure TRACTOR is on a level surface.
2. Drive TRACTOR for a few minutes.
3. Stop engine and wait a few minutes.
4. Remove right side of the foot plate.
5. Remove the fluid level check plug.
6. Place a fluid pan under the gearbox case, and then drain fluid completely by removing the drain plug.
7. Tighten the drain plug to 20 N.m.
8. Pour the specified fluid (GL-5 75W140) about 420mL by checking through the fluid level check plug hole until the fluid over flows.
9. Tighten the fluid level check plug to 20Nm.

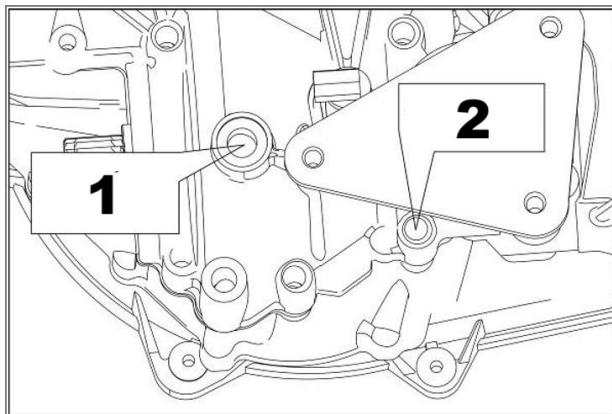

1 – Fluid level check plug

2 – Drain plug

## FRONT DIFFERENTIAL FLUID REPLACEMENT

To change the front differential fluid, ensure the TRACTOR is on a level position and carry out the following steps.

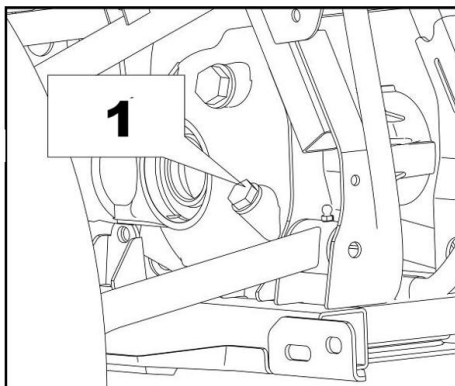

1 – Fluid level check plug

1. Clean the fluid level check plug area and remove the fluid level check plug.
2. Clean the drain plug area.
3. Place a fluid pan under the front differential case, and then drain fluid completely by removing the drain plug.
4. Tighten the drain plug to 20 N.m.
5. Pour the specified fluid (GL-5 80W90) about 180mL by checking through the fluid level check plug hole until the fluid over flows.
6. Tighten the fluid level check plug to 20 N.m.

## REAR DIFFERENTIAL FLUID REPLACEMENT

To change the rear differential fluid, ensure the TRACTOR is on a level position and carry out the following steps.

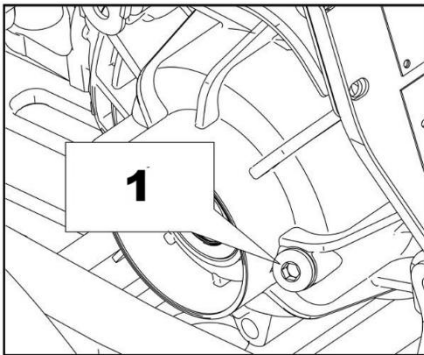

1 – Fluid level check plug

1. Clean the fluid level check plug area and remove the fluid level check plug.
2. Clean the drain plug area.
3. Place a fluid pan under the front differential case, and then drain fluid completely by removing the drain plug.
4. Tighten the drain plug to 20 N.m.
5. Pour the specified fluid (GL-5 80W90) about 400mL by checking through the fluid level check plug hole until the fluid over flows.
6. Tighten the fluid level check plug to 20 N.m

## SPARK PLUG

Spark plug condition is indicative of engine operation. Check the spark plug firing end condition after the engine has been warmed up and the TRACTOR has been driven at higher speeds. Immediately check the spark plug for correct color. If the electrode of the spark plug is appearing wet or dark color, replace the spark plug with a hotter type one. If it is white or appearing glazed, replace the spark plug. In case of carbon deposit, please use proper tools for cleaning.

Check the clearance of the spark plug – the gap has to be 0.7-0.9mm.

**WARNING!** A hot exhaust system and engine can cause burns. Wear protective gloves when removing a spark plug for inspection.

## RADIATOR

1. Check the radiator area for cleanliness.

2. Remove the front panel, front panel liner.

**CAUTION:** Never clean radiator with your hands when it is hot. Let the radiator cool down before cleaning.

3. Inspect the radiator and the hoses for leaks or any damage.

4. Inspect the radiator fins. They must be clean, free of mud, dirt, leaves and other deposit that would prevent the radiator to cool properly.

5. If available, use a garden hose to rinse the radiating fins.

**NOTE:** Be careful to not damage the radiator fins when cleaning. Do not use any object/tool that could damage the fins. When water from hosing, use low pressure only. Never use a high-pressure washer.

6. Install front panel and front panel liner.

## BATTERY

### Battery removal

The battery is located under the driver's seat.

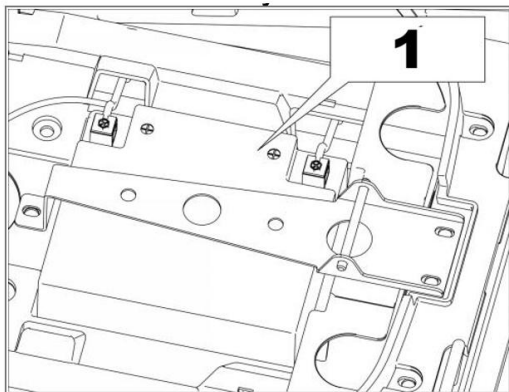

1 - Battery

1. Remove seat.

2. Remove battery cover.

3. Disconnect BLACK (-) cable first, then the RED (+) cable.

**NOTE:** Always respect this order for removal; disconnect BLACK (-) cable first.

4. Remove battery.

### **Cleaning the battery**

Clean the battery connectors, cables and battery posts using a solution of baking soda and water. Remove corrosion (if so) from battery cable terminals and battery posts using a firm wire brush. Rinse with clear water and dry well.

### **Inspecting the Battery**

Visually inspect battery casing for cracks or any other damages. If case of the battery is damaged, replace the battery and thoroughly clean battery support with a water.

Inspect condition of the battery posts, battery support, holding strap and strap attachment points and wire terminal lugs.

### **Installing the Battery**

NOTE: Always connect RED (+) cable first then BLACK (-) cable.

## **FUSE**

### **Fuse location.**

The fuse box is located under dash cover.

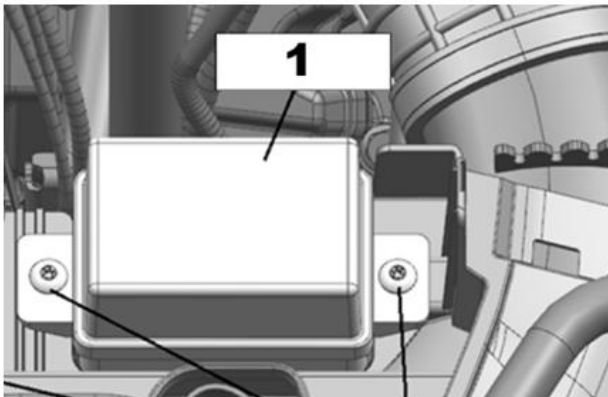

1 – Fuse box

### **Fuse Inspection**

Check fuse condition and replace it if it is necessary. To remove the fuse from holder, pull fuse cover out. Check if any fuse is burned.

## BRAKES

Check if any brake fluid is leaking out of the pipe joints or the brake fluid reservoir. Apply the brakes firmly for one minute and check if there is any leakage. When the leakage appear, contact an authorized dealer.

Test the brakes at slow speed after starting out to make sure they are working properly. If the brakes do not provide proper braking performance, do not use TRACTOR, contact an authorized dealer.

### Brake fluid level

Check brake fluid level by observing window of front brake container. Check if the fluid is between upper and lower limit line of rear brake fluid. If the brake fluid level drops below the minimum level, add DOT4 brake fluid to the container, just below the maximum level.

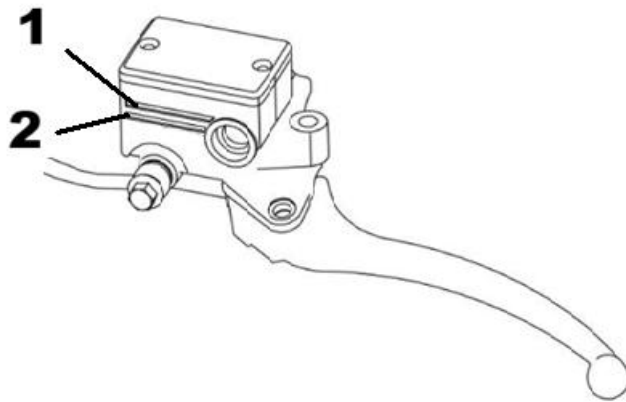

1 – high level of fluid

2 – low level of fluid

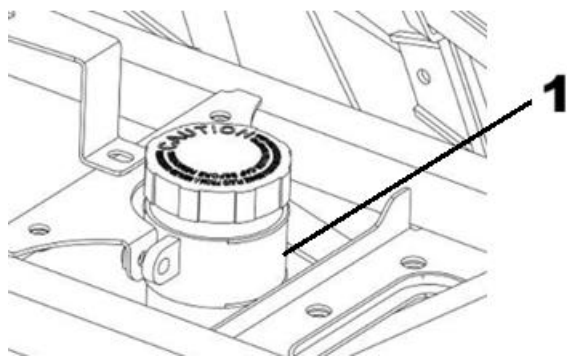

1 – transparent fluid contained

### Brake pedal adjustment

The brake pedal stroke is 30 ~ 40mm. If the stroke is less than 30mm, adjust the brake pin connecting the brake pedal.

## **Inspecting Brake System**

Before driving, always inspect the following:

- Brake fluid level
- Brake system for fluid leaks
- Brake pad wear
- Brake cleanliness

NOTE: The brake fluid replacement, brake system maintenance and repairs should be performed by an authorized dealer.

## SUSPENSION ADJUSTMENT

**WARNING!** The suspension adjustment could affect TRACTOR handling. Always take time to familiarize yourself with the TRACTOR's behavior after any suspension adjustment has been made.

Suspension adjustment and loading can have an effect on your TRACTOR handling and comfort.

The choice of the suspension adjustments might vary with driver's weight, personal reference, driving speed and field condition.

## SPRING PRELOAD ADJUSTMENT

**WARNING!** The left and right shock adjustment on front or rear suspension must always be set to the same position. Never adjust one only. The adjustment of one site only can cause poor handling and loss of stability which could lead to an accident.

### Shock absorption settings:

Adjust spring preload by turning adjustment cam.

1. Toward the position 3 to shorten the springs for a stiffer drive and rough conditions.
2. Toward the position 2 to lengthen the springs for a softer drive and smooth conditions.

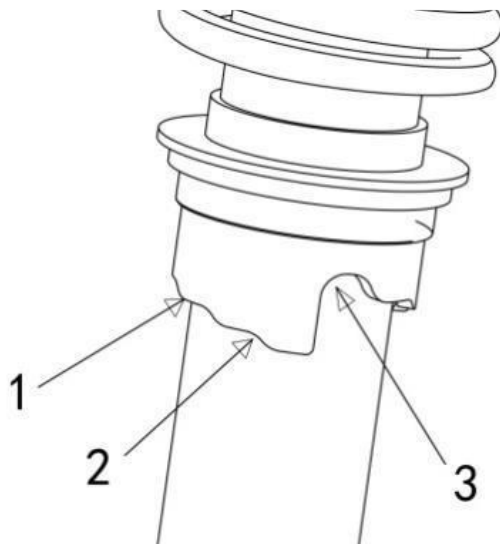

- 1 - Adjustment cam
- 2 - Stiffer adjustment
- 3 - Softer adjustment

## Airbag shock absorption

Compression damping controls the shock absorber's reaction while driving.

POSITION	SETTING	RESULT ON BIG BUMPS
1	Soft	Softer Compression damping
2	Medium (Factory)	Medium Compression Damping
3	Hard	Firmer Compression damping

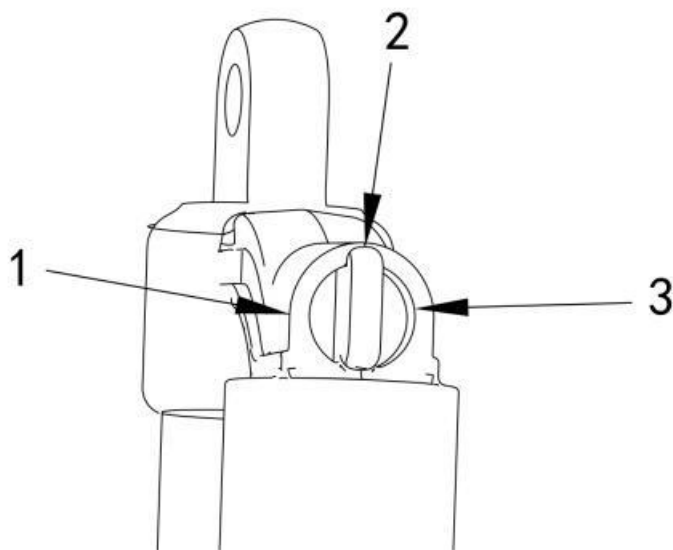

1 - position1

2 - position2

3 - position3

Turn the adjuster knob clockwise to increase shock damping action (stiffer).

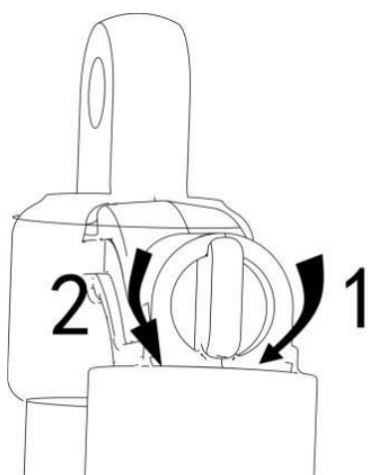

1 - Increases damping (stiffer)

2 - Decreases damping (softer)

Turn the adjuster knob counterclockwise to decrease shock damping action (softer).

## MUFFLER SPARK ARRESTER CLEANING AND INSPECTION

**WARNING!** Allow the exhaust system cool before proceeding with leaning and inspection.

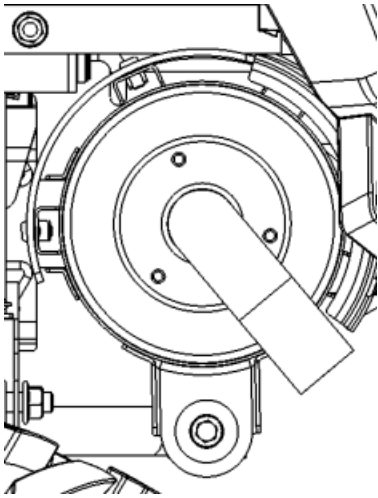

**Remove exhaust tail pipe, gasket (discard) and spark arrester.**

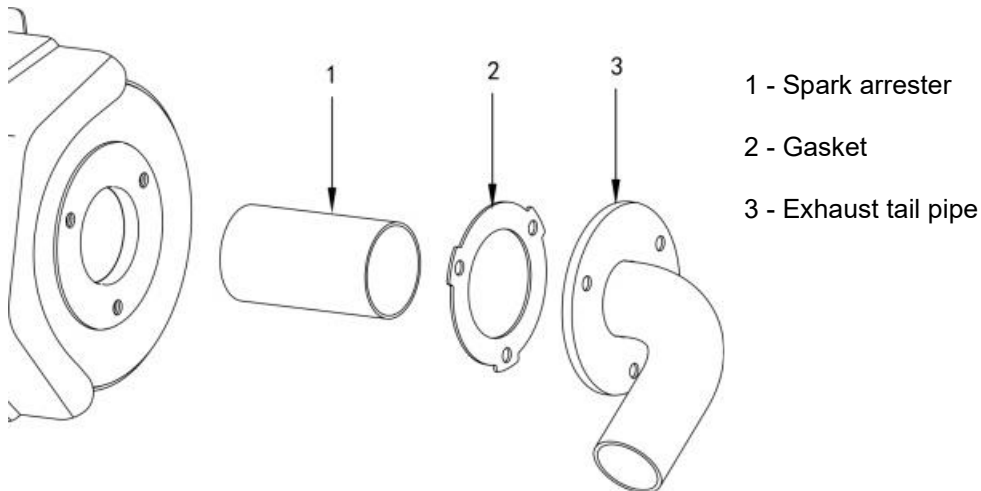

1 - Spark arrester

2 - Gasket

3 - Exhaust tail pipe

1. Remove carbon deposits from the spark arrester using a brush.

NOTE: Use a soft brush and be careful to avoid damaging spark arrester mesh.

**CAUTION:** Wear eye protection and gloves.

2. Inspect mesh of spark arrester for any damage. Replace if necessary.

3. Inspect spark arrester chamber in muffler. Clean any debris as required.

NOTE: Spark arrester screen replacement is required only when damaged

4. Install new gasket, tail pipe and new retaining screws.

5. Reinstall exhaust tail pipe with new retaining screws.

6. Tighten to specification.

## MAINTENANCE CHART

In order to maintain the best performance and economic performance of TRACTORS, tips are listed on the intervals for necessary regular maintenance. Subsequent maintenance is calculated in km and hours.

However, keep in mind that if the TRACTOR is not used for a long period of time, you should follow the monthly maintenance intervals.

Items marked with an asterisk must be performed by a dealer as they require special tools and technical skills.

In case of complicated road conditions, regular maintenance of the TRACTOR should be carried out.

**WARNING!** Indicates a potential hazard that, if not avoided, could result in serious injury or death.

If it is necessary to remove a locking device during disassembly/assembly, always replace it with a new one.

The maintenance is very important, if you are not familiar with safe service practices and adjustment procedures, see your authorized dealer.

ITEM	ROUTINE	CONDITIONS Whichever Comes first	INITIAL			EVERY		
			Month	1	3	6	6	12
			Kilometers	320	1,200	2,400	2,400	4,800
			Hours	20	75	150	150	300
Valves*	<ul style="list-style-type: none"> <li>• Check valve clearance.</li> <li>• Adjust if necessary.</li> </ul>		○		○	○	○	
Cooling system	<ul style="list-style-type: none"> <li>• Check coolant leakage.</li> <li>• Repair if necessary.</li> <li>• Replace coolant every 24 months.</li> </ul>		○	○	○	○	○	
Spark plug	<ul style="list-style-type: none"> <li>• Check condition.</li> <li>• Adjust gap and clean.</li> <li>• Replacement every 24 months</li> </ul>		○	○	○	○	○	
Air filter elements	<ul style="list-style-type: none"> <li>• Clean.</li> <li>• Replacement every 24 months</li> </ul>		Every 20-40 hours (More often in wet or dusty areas.)					
Crankcase breather system*	<ul style="list-style-type: none"> <li>• Check breather hose for cracks or damage.</li> <li>• Replace if necessary.</li> </ul>				○	○	○	
Exhaust system*	<ul style="list-style-type: none"> <li>• Check for leakage.</li> <li>• Tighten if necessary.</li> <li>• Replace gasket(s) if necessary.</li> </ul>				○	○	○	
Fuel line*	<ul style="list-style-type: none"> <li>• Check fuel hose for cracks or damage.</li> <li>• Replacement fuel hose every 48 months</li> <li>• Replacement fuel filter every 24 months</li> </ul>				○	○	○	
Engine oil	<ul style="list-style-type: none"> <li>• Replace (Check oil level every month)</li> </ul>		○		○	○	○	
Engine oil filter	<ul style="list-style-type: none"> <li>• Replace</li> </ul>		○		○		○	
Differential and gearbox oil	<ul style="list-style-type: none"> <li>• Check oil level/oil leakage.</li> <li>• Replacement every 24 months.</li> </ul>		○				○	

Brake*	<ul style="list-style-type: none"> <li>● Check operation/brake pad wear/fluid leakage.</li> <li>● Brake fluid needs to be above the lowest position.</li> <li>● Correct if necessary. Replace pads/disk if worn to the limit.</li> </ul>	○	○	○	○	○
Throttle lever*	<ul style="list-style-type: none"> <li>●Check operation and free play.</li> </ul>	○	○	○	○	○
Wheels*	<ul style="list-style-type: none"> <li>●Check balance/damage/ run out</li> <li>●Repair if necessary.</li> </ul>	○		○	○	○
Wheel bearings*	<ul style="list-style-type: none"> <li>●Check bearing assemblies for looseness or damage.</li> <li>●Replace if damaged.</li> </ul>	○		○	○	○
Front and rear Suspension*	<ul style="list-style-type: none"> <li>●Check operation and for leakage.</li> <li>●Correct if necessary.</li> </ul>			○		○
Steering system*	<ul style="list-style-type: none"> <li>●Check operation and for looseness</li> <li>●Replace if damage.</li> <li>●Check toe-in/Adjust if necessary.</li> </ul>	○	○	○	○	○
Rear knuckle pivots and suspension arms*	<ul style="list-style-type: none"> <li>●Lubricate with lithium-soap-based grease.</li> </ul>			○	○	○
Drive shaft universal joint*	<ul style="list-style-type: none"> <li>●Lubricate with lithium-soap-based grease.</li> </ul>			○	○	○
Engine mounting*	<ul style="list-style-type: none"> <li>●Check for cracks or damage.</li> <li>●Correct bolt tightness.</li> </ul>			○	○	○
Front and rear axle	<ul style="list-style-type: none"> <li>●Check operation.</li> <li>●Replace if damage.</li> </ul>	○				○
Stabilizer bushings*	<ul style="list-style-type: none"> <li>●Check for cracks or damage.</li> </ul>			○	○	○
Fittings and fasteners*	<ul style="list-style-type: none"> <li>●Check all chassis fittings and fasteners.</li> <li>●Correct if necessary.</li> </ul>	○	○	○	○	○
Battery	<ul style="list-style-type: none"> <li>●Check and clean end connection</li> </ul>	○		○	○	○
Light and turn signal	<ul style="list-style-type: none"> <li>●Operation</li> </ul>	○	○	○	○	○

## MAINTENANCE SCHEDULE

Maintenance is very important to keep your TRACTOR in safe operating condition.

The TRACTOR should be serviced as per the maintenance schedule.

Proper maintenance is the owner's responsibility. A warranty claim may be denied if, among other things, the owner or operator caused the problem through improper maintenance or use.

Perform periodic checks and follow the maintenance schedule. The maintenance schedule does not exempt the pre-drive inspection.

## AIR FILTER MAINTENANCE GUIDELINE

Air filter maintenance should be adjusted according to driving conditions.

Air filter maintenance must be increased in frequency when driving on snow, dry sand, dirt, gravel or similar conditions which have high dust or particle dispersion.

Driving in a group in these conditions will require increasing the air filter maintenance frequency further.

NOTE: Accessory filters and pre-filters are available for such conditions. Contact an authorized dealer for details.

**WARNING!** Failure to properly maintain the TRACTOR according to the maintenance schedule and procedures can make it unsafe to operate.

## SEVERE DUTY USE

If your TRACTOR is used in the following conditions, refer to the Severe Duty section of the maintenance schedule.

- Repeated towing of loads at more than 75% the maximum capacity.
- The increase workload applied to the drive system accelerates the differentials, gearbox/transmission, and engine oil life. This reduces internal component longevity if not replaced more frequently.
- Driving at excessive speeds for prolonged amount of time.

Higher than the average utility or commercial use requires more frequent fluid and wear component replacement than trail, recreational, or occasional utility purposes.

## EXTREME COLD CONDITION

An engine that is frequently operated at or below an ambient temperature of -25 °C will require an increase in service and maintenance schedule.

Any combustion engine operated at these low ambient temperatures will collect an increased amount of condensation at every startup/warm-up.

Since the engine is not reaching operating temperatures for extended periods of time, the oil is starting to be strongly diluted with water and gas residue (more water content).

An engine needs to reach operating temperature, in order to be able to evaporate condensate out of the oil.

If daily usage (work or leisure driving cycle) is similar to those mentioned below, we strongly recommend changing the oil at least once a month.

Parameters of an increase in service and maintenance schedule:

- Engine not reaching the proper operating temperature during normal daily usage
- Multiple starts and stops without reaching operating temperature
- Short idle periods
- Low RPM driving cycle in short distances without reaching operating temperature.

NOTE: The installation of a block heater to help warm up the liquids is strongly recommended, this will also help to extend the oil lifetime.

### MUD / WATER USE

The TRACTOR, which runs on mud and uses frequently to pass the water terrains, requires more frequent maintenance and inspections to ensure debris has not infiltrated mechanical components.

If you regularly drive in mud or water, refer to the Mud/ Water section of the maintenance schedule.

After every drive, be sure to perform the **Post Operation Care for Mud/Water Environment**.

### POST OPERATION CARE FOR MUD / WATER ENVIRONMENT

- Rinse the TRACTOR and its components with fresh water.
- Clean the CVT air filters.
- Drain the CVT compartment and clean if any water or mud is found.
- Inspect and clean engine air filters and engine air filter housing.
- Clean radiator.
- Visually inspect for any water accumulation in the vent hoses (fuel tank, gearbox, front differential and rear final drive). If there is water, bring the TRACTOR to your nearest authorized dealer for inspection and servicing of main components related to the vents.
- Clean front and rear shock absorbers to prevent seal from damage by dust or dirt.
- Clean drive shaft bellows and the propeller shaft yokes or boots.

### EXHAUST EMISSION SONTROL SYSTEM

Do not modify the engine, intake or exhaust components, as doing so may affect compliance with noise level requirements.

Exhaust emissions are controlled by engine design. An electronic fuel injection (EFI) system controls fuel delivery. The engine and EFI components are set at the factory for optimal performance and are not adjustable.

## MAINTENANCE SCHEDULE

Make sure to perform proper maintenance at recommended intervals as indicated in the tables.

The maintenance chart intervals are based on 3 factors:

- Calendar time
- TRACTOR hours
- Odometer reading

Take into account whichever comes first to determine the maintenance threshold.

Your driving habits determine the factors you shall adhere to.

### **For example:**

- Someone who uses their TRACTOR few times over the year would most likely follow the **calendar years** to determine the maintenance interval.
- Someone who uses their TRACTOR daily/weekly for long periods of time would most likely follow the **TRACTOR hours** to determine the maintenance interval.
- Someone who uses their TRACTOR 1-2days per week with light work would most likely follow the **odometer** reading to determine the maintenance interval.

**IMPORTANT:** The following tables show the appropriate maintenance application for the first 3 years. For subsequent years, repeat the same pattern alternatively.

<b>Regular Maintenance Overview</b>			
Calendar Years	TRACTOR Hours	Odometer	Actions for Regular Duty
1	200	3000	A
2	400	6000	A and B
3	600	9000	B
<b>Severe Duty and Mud/Water Maintenance Overview</b>			
Calendar Years	TRACTOR Hours	Odometer	Actions for Severe Duty and Mud / Water
0.5	100	1500km	A+
1	200	3000km	A+ and A
1.5	300	4500km	A+
2	400	6000km	A+ and A and B
2.5	500	7500km	A+
3	600	9000km	A+ and A

<b>REGULAR DUTY</b>	<b>A</b>	<b>B</b>
A = Adjust C = Clean I= Inspect L= Lubricate R= Replace T= Torque	<b>Every year</b> or 200 hours or 3000 km	<b>Every 2 year</b> or 400 hours or 6000 km
<b>Air and Fuel Delivery</b>		
Engine air filter	I,C	
Fuel tank vent filter	R	
Canister vent pre-filter (CARB and EVAP models)		R
Fuel components (fuel cap, hoses, clamps and tank fixation) and function*		I
Fuel pump pressure		I
<b>Body and Chassis</b>		
Cage fasteners	T	
<b>Engine and Cooling</b>		
Engine oil and filter	R	
Valve clearance	A (V-Twin engine)	A (1cyl.engine)
Coolant level and concentration	I,A	
Coolant	R *every 5years or 12000km	
Spark plugs		R
<b>Exhaust and Emissions</b>		
Exhaust components (gaskets, pipes and muffler) and function*	I,C	
Debris around exhaust pipe and muffler area	C	
Spark arrester	C	
<b>Regular duty</b>		
A = Adjust C = Clean I= Inspect L= Lubricate R= Replace T= Torque	<b>Every year</b> or 200 hours or 3000 km	<b>Every 2 year</b> or 400 hours or 6000 km
<b>Brake</b>		
Brake components and function*	I,C	
Brake fluid	R Every 2 year	
<b>Drive</b>		
Gearbox oil	Replace at first 3000 km and at 6000 km, then follow the regular schedule	
Gearbox oil	I	R
Drive components and function*	I	
Front differential oil	I	R
Rear final drive oil (Mono-cyl.engine)	I	R
<b>Continuously Variable Transmission (CVT)</b>		
CVT components and function*	I,C,L	
<b>Electrical</b>		
Various controls, switches, lights, module updates, fault codes, battery condition*	I	
TRACTOR speed sensor (VSS)		C
<b>Steering</b>		
Steering components and function*	I	
<b>Suspension</b>		
Suspension components and function*	I, L, T	
*For an extensive list of maintenance actions to be performed, refer to your local dealership.		

<b>SEVERE DUTY</b>	<b>A+</b>	<b>A</b>	<b>B</b>
A = Adjust C = Clean I= Inspect L= Lubricate R= Replace T= Torque	<b>Every 6months</b> or 100 hours or 1500km	<b>Every year</b> or 200 hours or 3000 km	<b>Every 2 year</b> or 400 hours or 6000 km
<b>Air and Fuel Delivery</b>			
Engine air filter	I,C	R	
Fuel tank vent filter		R	
Canister vent pre-filter (CARB and EVAP models)			R
Fuel components (fuel cap, hoses, clamps and tank fixation) and function*			I
Fuel pump pressure			I
<b>Body and Chassis</b>			
Cage fasteners		T	
<b>Engine and Cooling</b>			
Engine oil and filter	R		
Valve clearance			A
Coolant level and concentration		I,A	
Coolant	R *every 5years or 12000km		
Spark plugs			R
<b>Exhaust and Emissions</b>			
Exhaust components (gaskets, pipes and muffler) and function*		I,C	
Debris around exhaust pipe and muffler area	C		
Spark arrester	C		
<b>Brake</b>			
Brake components and function*		I,C	
Brake fluid		R Every 2 year	
<b>Drive</b>			
Gearbox oil	Replace at first 1500 km and at 3000 km, then follow the regular schedule		
Gearbox oil		R	
Drive components and function*		I	
Front differential oil		R	
Rear final drive oil		R	
<b>Continuously Variable Transmission (CVT)</b>			
CVT components and function*		I,C,L	
<b>Electrical</b>			
Various controls, switches, lights, module updates, fault codes, battery condition*		I	
TRACTOR speed sensor (VSS)			C
<b>Steering</b>			
Steering components and function*		I	
<b>Suspension</b>			
Suspension components and function*	I,L	T	
*For an extensive list of maintenance actions to be performed, refer to your local dealership.			

MUD / WATER	A+	A	B
A = Adjust C = Clean I= Inspect L= Lubricate R= Replace T= Torque	Every 6months or 100 hours or 1500km	Every year or 200 hours or 3000 km	Every 2 year or 400 hours or 6000 km
<b>Air and Fuel Delivery</b>			
Engine air filter		I,C	
Fuel tank vent filter		R	
Canister vent pre-filter (CARB and EVAP models)			R
Fuel components (fuel cap, hoses, clamps and tank fixation) and function*			I
Fuel pump pressure			I
<b>Body and Chassis</b>			
Cage fasteners		T	
<b>Engine and Cooling</b>			
Engine oil and filter	I	R	
Valve clearance			A
Coolant level and concentration		I,A	
Coolant		R *every 5years or 12000km	
Spark plugs			R
<b>Exhaust and Emissions</b>			
Exhaust components (gaskets, pipes and muffler) and function*	I,C		
Debris around exhaust pipe and muffler area	C		
Spark arrester	C		
<b>Brake</b>			
Brake components and function*	I,C		
Brake fluid		R Every 2 year	
<b>Drive</b>			
Gearbox oil	Replace at first 1500 km and at 3000 km, then follow the regular schedule		
Gearbox oil	I		R
Drive components and function*	I		
Front differential oil	I		R
Rear final drive oil	I		R
<b>Continuously Variable Transmission (CVT)</b>			
CVT components and function*		I,C,L	
<b>Electrical</b>			
Various controls, switches, lights, module updates, fault codes, battery condition*		I	
TRACTOR speed sensor (VSS)			C
<b>Steering</b>			
Steering components and function*	I		
<b>Suspension</b>			
Suspension components and function*	I,L	T	
*For an extensive list of maintenance actions to be performed, refer to your local dealership.			

## TROUBLESHOOTING

### SYMPTOM: Engine does not turn

POSSIBLE CAUSES	WHAT TO DO
1. Ignition switch is in the OFF position.	Place switch to ON position.
2. Burnt fuse.	Check main fuse condition.
3. Weak battery or loose connections.	Check charging system fuse. Check connections and terminals condition. Have the battery checked. Contact an authorized dealer.

### SYMPTOM: Engine turns over but fails to start

POSSIBLE CAUSES	WHAT TO DO
1. Burnt fuse.	Check main fuse condition.
2. No fuel to the engine (spark plug dry when removed).	Check fuel tank level: turn fuel valve to ON (also try on RES). A failure of the fuel pump may have occurred. Contact an authorized dealer.
3. Spark plug/ignition (no spark).	Check main fuse condition. Remove spark plug then reconnect to ignition coil. Check that ignition switch and/or engine stop switch is/are at the ON position. Start engine with spark plug grounded to engine away from spark plug hole. If no spark appears, replace spark plug. If trouble persists, contact an authorized dealer.

### SYMPTOM: Engine lacks acceleration or power

POSSIBLE CAUSES	WHAT TO DO
1. Fouled or damaged spark plug.	Replace a new spark plug.
2. Lack of fuel to engine.	Refill fuel.
3. Engine is overheating.	Check ENGINE OVERHEAT in PROCEDURES. If overheating persists, contact an authorized dealer.
4. Air filter/box plugged or dirty.	Check air filter and clean if necessary.

	<p>Check deposits in air box drain.</p> <p>Check the position of the air intake tube.</p>
5. CVT dirty or wear.	Contact an authorized dealer.

**SYMPTOM: Transmission lever is hard to move**

POSSIBLE CAUSES	WHAT TO DO
1. Transmission gears are in a position that prevents the transmission lever to work.	Rock the TRACTOR back and forth to move the gears in the transmission and allow the transmission lever to be set.
2. CVT dirty or wear.	Contact an authorized dealer.

**SYMPTOM: The RPM increases but the TRACTOR does not move**

POSSIBLE CAUSES	WHAT TO DO
1. The transmission is P or N position.	Select the H or L position.
2. CVT is defective	Contact an authorized dealer.
3. Water in the CVT housing.	Contact an authorized dealer.

**SYMPTOM: Engine backfire**

POSSIBLE CAUSES	WHAT TO DO
1. Exhaust system leakage.	Contact an authorized dealer.
2. Ignition timing is incorrect or there is an ignition system failure.	Contact an authorized dealer.

**SYMPTOM: TRACTOR cannot reach full speed**

POSSIBLE CAUSES	WHAT TO DO
1. Engine.	See ENGINE LACKS ACCELERATION OR POWER.
2. Air filter/box plugged or dirty.	Check air filter and clean if necessary.

	<p><b>Check deposits in air box drain.</b></p> <p><b>Check the position of the air intake tube.</b></p>
<b>3. CVT dirty or wear.</b>	<b>Contact an authorized dealer.</b>

<b>SYMPTOM: Engine misfire</b>	
<b>POSSIBLE CAUSES</b>	<b>WHAT TO DO</b>
<b>1. Fouled/damaged/worn spark plug</b>	<b>Clean/verify spark plug and heat range.</b>
<b>2. Water in fuel.</b>	<b>Drain fuel system and refill with fresh fuel.</b>

## FAULT CODES

A fault code is an indication that a glitch or malfunction is detected by the self-diagnostic system.

Read fault code: Remove the upper cover of engine hood and look for the harness connector of fault diagnosis tester beside the ECU.

Unplug the protector, connect the fault diagnosis tester by special data cable.

Turn on the fault diagnosis tester and read fault code.

### CODE FAULT

<b>P0107</b>	<b>MAP Circuit Low Voltage or Open</b>
<b>P0108</b>	<b>MAP Circuit High Voltage</b>
<b>P0112</b>	<b>IAT Circuit Low Voltage</b>
<b>P0113</b>	<b>IAT Circuit High Voltage or Open</b>
<b>P0117</b>	<b>Coolant/Oil Temperature Sensor Circuit Low Voltage</b>
<b>P0118</b>	<b>Coolant/Oil Temperature Sensor Circuit High Voltage or Open</b>
<b>P0122</b>	<b>TPS Circuit Low Voltage or Open</b>
<b>P0123</b>	<b>TPS Circuit High Voltage</b>
<b>P0131</b>	<b>O2S 1 Circuit Low Voltage</b>
<b>P0132</b>	<b>O2S 1 Circuit High Voltage</b>
<b>P0032</b>	<b>O2S Heater Circuit High Voltage</b>
<b>P0031</b>	<b>O2S Heater Circuit Low Voltage</b>
<b>P0201</b>	<b>Injector 1 Circuit Malfunction</b>
<b>P0202</b>	<b>Injector 2 Circuit Malfunction</b>
<b>P0230</b>	<b>FPR Coil Circuit Low Voltage or Open</b>
<b>P0232</b>	<b>FPR Coil Circuit High Voltage</b>
<b>P0336</b>	<b>CKP Sensor Noisy Signal</b>
<b>P0337</b>	<b>CKP Sensor No Signal</b>
<b>P0351</b>	<b>Cylinder 1 Ignition Coil Malfunction</b>
<b>P0352</b>	<b>Cylinder 2 Ignition Coil Malfunction</b>
<b>P0505</b>	<b>Idle Speed Control Error</b>
<b>P0562</b>	<b>System Voltage Low</b>
<b>P0563</b>	<b>System Voltage High</b>
<b>P0650</b>	<b>MIL Circuit Malfunction</b>
<b>P1693</b>	<b>Tachometer Circuit Low Voltage</b>
<b>P1694</b>	<b>Tachometer Circuit High Voltage</b>
<b>P0137</b>	<b>O2S 2 Circuit Low Voltage</b>
<b>P0138</b>	<b>O2S 2 Circuit High Voltage</b>
<b>P0038</b>	<b>O2S Heater 2 Circuit High Voltage</b>
<b>P0037</b>	<b>O2S Heater 2 Circuit Low Voltage</b>
<b>P0500</b>	<b>VSS No Signal</b>
<b>P0850</b>	<b>Park Neutral Switch Error</b>
<b>P0445</b>	<b>CCP short to high</b>
<b>P0444</b>	<b>CCP short to low/open</b>

## WARRANTY

ANTHER EUROPE gives a TWO YEAR LIMITED WARRANTY on all components of your TRACTOR against defects in material or workmanship.

This warranty covers parts and labor charges for repair or replacement of defective parts and begins on the date of purchase by the original retail purchaser. The duration of this warranty may vary by international region based upon local laws and regulations.

## REGISTRATION

At the time of sale, the Warranty Registration Form must be completed by your dealer and submitted to ANOTHER EUROPE within ten days of purchase. Upon receipt of this registration, ANOTHER EUROPE will record the registration for warranty. No verification of registration will be sent to the purchaser as the copy of the Warranty Registration Form will be your proof of warranty coverage. If you have not signed the original registration and received the customer copy, please contact your dealer immediately. **NO WARRANTY COVERAGE WILL BE ALLOWED UNLESS YOUR TRACTOR IS REGISTERED WITH ANOTHER EUROPE.** Initial dealer preparation and set-up of your TRACTOR is very important in ensuring trouble-free operation.

## OWNER'S WARRANTY RESPONSIBILITIES

As the TRACTOR owner, you are responsible for the performance of the required maintenance listed in your owner's manual. ANOTHER EUROPE recommends that you retain performance of all scheduled maintenance.

You are responsible for presenting your TRACTOR to an ANOTHER EUROPE dealer as soon as a problem presents itself. The warranty repairs should be completed in a reasonable amount of time, not to exceed 30 days.

As the TRACTOR owner, you should be aware that ANOTHER EUROPE may deny your warranty coverage if your TRACTOR or a part has failed due to abuse, neglect, improper maintenance or unapproved modifications.

If you use your TRACTOR in any type of sanctioned competitive event, this warranty is immediately and completely void.

If you have any questions regarding your warranty rights and responsibilities, you should contact ANOTHER EUROPE

### I. Coverage.

Warranty defects shall be remedied during customary business hours at any authorized ANOTHER EUROPE dealer located within EUROPE.

### II. Agency.

Any part or parts replaced under this warranty shall become the property of ANOTHER EUROPE.

II. Limitations This Emission Control System Warranty shall not cover any of the following:

A. Repair or replacement as a result of:

(1) accident,

(2) misuse,

(3) repairs improperly performed or replacements improperly installed.

(4) use of replacement parts or accessories not conforming to ANOTHER EUROPE's specifications which adversely affect performance and/or

(5) use in competitive racing or related events.

B. Inspections, replacement of parts and other services and adjustments required for required maintenance.

C. Any TRACTOR equipped with an odometer or hour meter on which the odometer mileage or hour meter reading has been changed so that actual mileage cannot be readily determined.

### III. Limited Liability

A. The liability of ANOTHER EUROPE under this emission control system warranty is limited solely to the remedying of defects in material or workmanship by an authorized ANOTHER EUROPE dealer at its place of business during customary business hours. This warranty does not cover inconvenience or loss of use of the TRACTOR or transportation of the TRACTOR to or from the ANOTHER EUROPE dealer. ANOTHER EUROPE shall not be liable for any other expenses, loss or damage, whether direct, incidental, consequential or exemplary arising in connection with the sale or use of or inability to use the TRACTOR for any purpose.

B. No express emission control system warranty is given by us except as specifically set forth herein. Any emission control system warranty implied by law, including any warranty of merchantability or fitness for a particular purpose, is limited to the express emission control system warranty terms stated in this warranty. The foregoing statements of warranty are exclusive and in line with all other remedies.

C. No dealer is authorized to modify this ANOTHER EUROPE Limited Emission Control System Warranty.

IV. Legal Rights. This warranty gives you specific legal rights, and you may also have other rights which vary from country.

V. Additional Information. Any replacement part that is equivalent in performance and durability may be used in the performance of any maintenance or repairs. However, ANOTHER EUROPE is not liable for these parts. The owner is responsible for the performance of all required maintenance. Such maintenance may be performed at a service establishment or by any individual. The warranty period begins on the date the motorcycle is delivered to the ultimate purchaser.

## TECHNICAL SPECIFICATIONS

<b>Dimensions</b>	<b>Variant 650</b>	<b>Variant 800</b>	<b>Variant 1000</b>
Length (mm)	2450		
Width (mm)	1246		
Wheel base (mm)	1500		
Ground clearance (mm)	255mm with 26"tyre, 265mm with 27"tyre		
Curb weight (kg)	462-470 kg (depends on tyre)	462-470 kg (depends on tyre)	474-482 kg (depends on tyre)
<b>Engine</b>			
Displacement (cc)	650cc	800cc	976cc
Number of cylinders	2		
Cycle	Four-stroke		
Cooling	Water		
Number of valves	4 per cylinder		
Maximum power (kW)	33.6 kW	36 kW	48 kW
Piston stroke (mm)	61.5 mm	61.5 mm	75 mm
Cylinder diameter (mm)	82 mm	91 mm	91 mm
Compression ratio	10.3±0.5:1	10.3±0.5:1	10.5±0.5:1
Fuel Type	Gasoline E5 E10, Min 92 octane		
Lubrication	Oil Filled with Internal Pump		
Power On	Electric		
Fuel system	EFI electronic fuel injection		
Control unit	Electronic		
Spark plug	DCPR7E / NGK	DCPR7E / NGK	CPR8EA-9
Engine oil capacity (mL) / Type of oil	2200 mL / SAE 10W 40SJ		
<b>TRANSMISSION</b>			
Variator	CVT (Continue Variable Transmission)		
Belt material / Width (mm)	Rubber / 30mm		
Gears	L (Slow), H (Fast), N (Neutral), R (Rear), P (Parking)		
Gearbox fluid capacity (mL) / Fluid type	420 mL / (GL-5 75W140)		
<b>WHEELS</b>			
Front tire	26x9-14 / 27x9-14		
Rear tire	26x11-14 / 27x11-14		
Front tire (ABS version)	26x9-14	26x9-14	27x9-14
Rear tire (ABS version)	26x11-14	26x11-14	27x11-14
Front rim	14x7		
Rear rim	14x8		
Front tire pressure (bar)	0.45 bar		
Rear tire pressure (bar)	0.45 bar		
<b>TOWING CAPACITY AND LOADS</b>			
Maximum total laden mass of TRACTOR (kg)	661kg		
Maximum towable trailer mass without trailer brakes (kg)	1025 Kg		
Maximum load on the front rack (kg)	30 Kg		
Maximum load on the rear rack (kg)	60 Kg		
Maximum vertical load on towbar (kg)	45 Kg		
Maximum load	2 people		
<b>Brakes</b>			
Front	Hydraulic discs		
Posterior	Hydraulic discs		
Brake calipers	Oil		
<b>Suspension</b>			
Front / Rear	A-arm independent / A-arm independent		
Springs	Helical and oil filled shock absorbers		
Front shock absorber travel (mm)	128 mm		
Rear shock absorber stroke (mm)	140 mm		
Traction	2 and 4 wheel drive		
Differential lock	Front		
<b>Electrical system</b>			
Voltage (V)	12 V		





ANTHER EUROPE S.R.L.  
Viale Lombardia 6, 20843 Verano Brianza (MB)  
C.F. e P.IVA 14368160967  
[info@anthereurope.com](mailto:info@anthereurope.com)

